

Initial Draft: October 15, 2013
Final Revision: March 21, 2014

Apurva Patil, P.E.
Remedial Project Manager
Remediation & Site Response Program
Toxic Substances Division
District Department of the Environment
1200 First Street, NE, 5th Floor
Washington, DC 20002

*Subject: **Remedial Investigation and Feasibility Study Work Plan Addendum #1 –
Monitoring Well Installation Activities; Benning Road Facility, 3400 Benning Road,
NE, Washington, DC***

Dear Ms. Patil:

AECOM has prepared this Addendum to the Benning Road Site Remedial Investigation and Feasibility Study (RI/FS) Work Plan to describe the proposed Phase III field activities at the Benning Road Site (the Site). The general site location is shown on **Figure 1**. The RI/FS Work Plan for the Site was approved by the District Department of the Environment (DDOE) in December 2012. In accordance with the process described in the RI/FS Work Plan, sampling data from the Phase I and Phase II landside investigation activities have been evaluated to determine the number and locations of groundwater monitoring wells. Accordingly, this Addendum has been prepared to discuss the Phase III landside investigation activities, specifically: (1) the number, location, and construction details for the proposed monitoring wells; and (2) the collection of hydrogeologic and chemical data from the monitoring wells.

Preliminary findings from the Phase I and Phase II investigations related to groundwater are also discussed in this Addendum. However, it should be noted that these findings are preliminary, based on sampling data that has not yet been validated, and are subject to change as more information becomes available. A summary of the Phase I and Phase II activities and preliminary observations as they relate to groundwater are discussed in the following paragraphs, followed by a description of the proposed Phase III investigation activities and schedule.

Summary of Phase I and Phase II Investigation Activities

To date, AECOM has completed the following field investigative activities:

- Surface soil sampling at twenty-five (25) locations (Phase I);
- Storm drain sampling (Phase I);
- Electrical resistivity imaging (ERI) along ten (10) transects (Phase I);
- Ten direct push technology (DPT) borings to calibrate the ERI electrical signals (Phase I);
- Five (5) soil borings (Phase I); and
- Thirty-seven (37) DPT borings to collect soil and groundwater samples (Phase II).

Field sampling locations completed during the Phase I and Phase II investigations are shown on **Figure 2**. The following is a summary of our preliminary observations from the data collected during the Phase I and Phase II activities:

Geology/Hydrogeology

1. The investigations confirmed the occurrence of an upper Patapsco formation underlain by the Arundel clay unit as described in the RI/FS Work Plan. The Arundel clay is located approximately 40 to 60 ft below grade. Stronger resistivity gradients were generally observed at the boundary of the Arundel clay during the ERI investigation.
2. The resistivity values detected at the site during the ERI investigation, visual observations, and geotechnical results are consistent with the expectation for the predominantly interbedded silt, sand, clay, and gravel materials in the Patapsco formation.
3. The Patapsco formation exhibits two water bearing zones across the site, potentially separated by a semi-continuous silt-clay layer. These two zones are referred to as upper water-bearing zone (UWZ) and lower water-bearing zone (LWZ).
4. The water table in the UWZ was generally observed between 5 and 15 ft below grade.
5. Based on the measurements of groundwater levels during Phases I and II, it appears that groundwater across the Site generally flows in a west-southwesterly direction, towards the Anacostia River. However, due to the tidal influence of the Anacostia River, groundwater flow on the Site may at times shift or reverse.

Occurrence of Chemical Constituents

1. ERI activities coupled with the data collected from DPT borings to confirm composition of geophysical anomalies observed during ERI indicated that there were no likely free product [light non-aqueous phase liquids (LNAPL) or dense non-aqueous phase liquids (DNAPL)] pools at the locations investigated.
2. Certain shallow subsurface soils at the Site are impacted with poly-cyclic aromatic hydrocarbons (PAHs) and fuel hydrocarbons (location dependent).
3. No semi-volatile organic compounds (SVOCs) other than PAHs were detected above the applicable screening levels provided in Table 2 of the RI/FS Quality Assurance Project Plan.
4. Various metals were detected across the site in soil and, to a lesser extent, in the groundwater.
5. Poly-chlorinated biphenyl (PCB) aroclors and PAHs in groundwater were detected in the western portion of the Site around Target Areas 1 and 13.
6. Estimated concentrations of pesticides, dioxins and furans below method reporting limits were reported at isolated locations. It is possible that some of these concentrations could be false positives.
7. Tetrachloroethylene (PCE), a volatile organic compound (VOC), was detected at a low concentration (160 parts per billion) at one location near the southern property boundary (DP-09). Lower concentrations of PCE, well below the screening levels, were reported at multiple locations.

Preliminary site-wide geologic cross-sections were created using historic soil borings, and data collected during the Phase I and Phase II investigations. These cross-sections are provided in **Figure 3**, and the locations of the cross-section lines are presented in **Figure 4**. The number, locations and construction details of proposed monitoring wells and proposed Phase III analytical program were determined based on the results of the ERI, geotechnical, and DPT investigative activities summarized above.

Phase III Investigation Activities

AECOM proposes the installation of monitoring wells (MWs) at 15 locations on the Site. In consideration of the presence of two water-bearing zones within the Patapsco formation observed during the Phase I and II investigation, AECOM proposes to install nested well sets with two well casings within a single borehole at each location, each screened at a different depth corresponding, respectively, to the UWZ and LWZ, depending on location-specific hydrogeologic characteristics. Construction details and specific rationale for each of the proposed MW sets are provided in **Table 1**, and their locations are shown on **Figure 2**. Well locations and screen interval depths are proposed based on Phase I and Phase II observations and are subject to change based on field conditions and observed lithologic characteristics at the time of well installation. In addition, AECOM proposes additional Geoprobe/Hydropunch groundwater sampling to better delineate PCE concentrations and identify potential sources near DP-09.

Permitting

It is our understanding that DCRA well permits are not required for the installation of the proposed monitoring wells or Geoprobe borings in accordance with the on-site exemption granted by the D.C. Act 18-720. Approval of this work plan by the DDOE will be sufficient for MW installation unless Pepco/AECOM is directed otherwise by the DDOE.

Monitoring Well Locations

As summarized in Table 1, the proposed monitoring well locations were selected for the purpose of perimeter monitoring of groundwater flow, evaluation of on-site groundwater quality, or both. The perimeter wells are situated along the Site boundaries to assess groundwater flowing into or off of the Site. These wells are critical to evaluating the quality of (a) groundwater flow onto the Site, including potential impacts originating on adjacent properties to the north and east, (b) groundwater flow from the Site to adjacent properties to the south, and (c) potential groundwater discharge to the Anacostia River to the west of the Site. Interior monitoring wells are intended to further evaluate the presence of PCBs, PAHs, pesticides, and dioxins/furans that were detected in DPT samples collected during the Phase II investigation. The network of monitoring wells will also provide the hydrogeologic data necessary to create an accurate groundwater contour map for the Site.

Of the 15 proposed monitoring well sets, eight well sets will be used for perimeter monitoring (MW-01, MW-02, MW-03, MW-04, MW-11, MW-12, MW-14, and MW-15), four wells will be used for on-site constituent monitoring (MW-06, MW-07, MW-10, and MW-13), and three wells will be used for both perimeter and constituent monitoring (MW-05, MW-08 and MW-09). The locations of these wells are shown on **Figure 2**. The total number and location of wells is also sufficient to evaluate the groundwater flow across the Site.

PCE Delineation near DP-09

During the Phase II investigation, PCE was detected in groundwater at a concentration of 160 parts per billion in the 25 to 30 ft interval of boring DP-09, near the southern property boundary. Additional groundwater delineation is proposed for this area to help identify a possible PCE source and determine the appropriate location for MW-07. Preliminary geologic cross-sections prepared for the DP-09 area from historic and Phase I and Phase II soil borings are provided in **Figure 5**.

Geoprobe/Hydro-punch groundwater screenings will be performed at a number of locations along the site southern perimeter and around DP-09. Boring DP-09 is bounded on three sides on-site by DP-06 (to the east), DP-12 (to the north) and DP-14 (to the west), none of which exhibited any detectable PCE

concentrations. Therefore, the investigation area will be limited to the area bounded by these three borings and the southern property boundary.

We propose to implement a gridded sampling approach around DP-09 in an iterative fashion. **Figure 2** illustrates the general concept of the sampling grid with 14 boring locations. A total of eight (8) initial borings will be placed around DP-09 and along the southern property boundary (see **Figure 2**). Geologic logs will be prepared for a minimum of four (4) boring locations to confirm the depth(s) to the silt-clay layers in the UWZ.

Typically, the groundwater samples will be collected within a two to five-foot interval above the top of the silt-clay layer located at approximately 30 ft bgs which separates the UWZ and the LWZ. In addition, if a shallower clay lens is identified within the saturated portion of the UWZ at any of the four lithologic borings, a second groundwater sample will be collected immediately above the clay lens. Multi-level groundwater samples will be collected at additional locations, if the data collected indicates the potential presence of an on-site source. Grab samples of groundwater will be collected using an inertial pump or a mini bailer. The samples will be screened for PCE and its degradation products: Trichloroethene, Vinyl Chloride, 1,2-Dichloroethene, cis-1,2-Dichloroethene, and trans-1,2-dichloroethene. The analyses will be conducted using either an on-site laboratory (depending on availability) or an expedited turn-around analysis at a fixed laboratory via EPA method 8260 or equivalent field method.

The eight initial boring locations constitute the minimum number of borings, and from here the sampling grid will be expanded outward based on the following decision logic:

- If the onsite initial boring data indicates PCE concentration greater than three times that of DP-09, then the sampling grid around the new maximum will be repositioned and a new set of initial borings will be installed.
- If higher PCE concentrations are detected at the southern boundary, then the source is potentially located offsite. Further repositioning of grid is not necessary, once a determination is made in consultation with DDOE that the source of PCE is likely located off site from the Pepco property,
- Otherwise, the sampling grid on site will then be expanded until the outermost ring of borings exhibit PCE and/or its daughter product concentrations down to a level of 30-50 ppb.

The results of the initial round of Geoprobe groundwater sampling around DP-09 will dictate the need for and direction of additional boring locations in accordance with the field logic discussed above. Once the extent of PCE in the UWZ is defined, Pepco will attempt LWZ sampling at up to four locations to the depths practicable using Geoprobe™. The sampling data will be used to determine if a source is present on-site, off-site, or if the detection at DP-09 is a localized occurrence. The data will also be used to interpret the extent of PCE in groundwater at the site.

Well Construction, Testing, and Sampling

The MWs will be installed, developed, tested and sampled following the procedures described in **Section 5.2** of the RI/FS Work Plan under Phase III, Tasks 1 through 3. The RI/FS Work Plan assumed the use of hollow stem auger method (HSA) for the drilling and installation of monitoring wells. Based on the observations during Phase I and Phase II drilling activities, the HSA drilling method would not be effective due to running sands and gravels in the subsurface. Pepco has evaluated other drilling methods such as mud rotary and Rotasonic drilling. The Rotasonic drilling method has been selected

due to its suitability to the site conditions, capability to produce continuous cores that would help with effective well construction, and reduced waste generation. UWZ and LWZ wells will be constructed as nested wells inside one borehole. Specific well construction details are presented in **Figure 6**, and the construction sequence is presented in **Figure 7**. All well construction activities will conform to D.C. guidance and well specifications.

Each proposed nested monitoring well location will be first characterized for lithology onsite by advancing a 4-inch core sampler and 6-inch Sonic Casing (on 10-foot intervals) to the desired terminal depth, providing continuous cores for evaluation. A field geologist will log the lithology for the core sections and will determine the positioning of the lower and upper well screens. Next the driller will advance an 8-inch Sonic isolation (over-riding the 6-inch casing at the deeper setting) to the total depth of the shallow well. Then the two-inch lower well will be constructed through the 6-inch temporary casing using 2-inch PVC screen and riser as appropriate with sand pack introduced in the 4-inch annulus to 2-feet above the screened interval. The 6-inch temporary casing will be retracted following the well construction to the bottom of the upper zone. Above the sand pack and at the clayey silt interface, a bentonite seal will be set to prevent intermixing between the two water bearing zones using bentonite chips/pellets. Following the curing/hydration of the bentonite seal, the 6-inch drill casing will be removed from the location entirely leaving the 8-inch casing in place for the installation of the shallow well. The shallow well will be constructed using 2-inch PVC screen and riser, with clean sand pack in the 6-inch annulus to 2-feet above the screen interval (allowing for the deep well riser pipe). Once fully constructed, the 8-inch temporary casing will be retracted. The well will be completed with a bentonite seal above the well screen, bentonite/cement grout to surface and flush mount locking well cap and cover. If the examination of the core during well installation reveals free NAPLs, drilling will cease, the borehole will be backfilled with bentonite grout, and Pepco, in consultation with DDOE will determine an alternative location for the well.

Based on the preliminary observations of the Phase I and Phase II data, Pepco will perform one round of groundwater sampling for the following parameters:

- All MWs will be sampled for PCBs (Method 8082), total and dissolved metals, and VOCs (Method 8260), EPA 16 PAHs (Method 8270), SVOCs (8270), and pesticides.
- A subset of up to 16 individual wells will be sampled for dioxins and furans.
- Forensic analyses have not been performed on Phase II samples. Therefore, it is proposed that up to five (5) MW groundwater samples be selected for forensic analysis for PCB congeners and PAH fingerprinting.

The MWs are proposed to be sampled by use of HydraSleeve™ passive grab samplers. The HydraSleeve is a single use (disposable) sampling device designed to collect groundwater samples directly from a desired screened interval of a well without having to purge the well prior to sample collection. Physically, the HydraSleeve consists of a section of lay-flat polyethylene tubing, sealed at the bottom end, and with a check valve at the top end. The sampler collects a sample from the desired interval only, with minimal mixing of fluids from other depths. After positioning the HydraSleeve at the bottom of the desired sampling interval, the sampler is activated by pulling it upwards at a rate of approximately 1 foot per second. When the sampler is full, the check valve closes, excluding any more water from entering. Further information about the HydraSleeve sampler can be found online at www.hydrasleeve.com. The HydraSleeve sampler is manufactured by GeolInsight of New Mexico. A Standard Operating Procedure (SOP) supplied by the manufacturer along with the operating manual is provided as **Attachment A**.

HydraSleeve samplers are proposed for use in sampling the on-site permanent monitoring wells because of the following advantages:

- The HydraSleeve is able to collect targeted groundwater samples from specific intervals within the well screen that other sample collection methods such as low-flow sampling can not achieve.
- The HydraSleeve is a no-purge sampling method, eliminating the need for disposal of investigation-derived waste in the form of purge water.
- Groundwater samples collected by the HydraSleeve have been shown to have as high a quality or higher than samples collected by conventional methods, and are more representative of the conditions at the depth from which the samples are collected because there is minimal mixing of the water column in the well during the collection process.
- Sample collection by use of a HydraSleeve is quicker and less expensive than most other sample collection methods.
- The HydraSleeve methodology is also more energy efficient.

With the exception of dioxins and furans, the range of analytes listed above requires a minimum sample volume of approximately 2.0 liters for analysis. Pepco proposes to collect the majority of groundwater samples using a 5-foot long, 2.25-liter HydraSleeve (HydraSleeve SS 2-L). For samples that require a greater sample volume, such as those that include dioxin/furan analysis or a field duplicate, a 7-foot long, 4-liter HydraSleeve (HydraSleeve SS 4-L) will be used. The HydraSleeve will be deployed to the depth interval where there was a previous detection during Phase II sampling. If there were no previous detections at the location, the middle of the screened interval will be targeted. A portion of the sample will be set aside to measure field parameters (i.e., turbidity, temperature, pH, dissolved oxygen, oxidation-reduction potential, and specific conductance). If there is insufficient volume of water in a single HydraSleeve to measure field parameters, a second HydraSleeve will be deployed in the well for this purpose. All samples will be packaged on ice, documented with a chain-of-custody, and submitted to a fixed laboratory for analysis.

Investigation-Derived Waste (IDW) Management

Investigation-derived wastes (IDW) generated during the monitoring well installation activities include the following:

- Disposable material such as personal protective equipment (PPE), plastic sheeting, etc.
- Drill cuttings
- Excess soil/sediment leftover from sampling activities
- Well development water
- Purge water
- Decontamination water

IDW will be managed as outlined in **Section 5.2.3** of the RI/FS Work Plan.

Schedule and Reporting

The Phase III field activities will begin within two weeks of DDOE's approval of this Addendum. A discussion of the Phase III field activities and results will be included in the draft RI Report.

If you have any questions or comments concerning this RI/FS Addendum, please contact Fariba Mahvi of Pepco at (202) 331-6641 or Ravi Damera of AECOM at (240) 565-6510.

Sincerely,



Ben Daniels
Staff Geologist

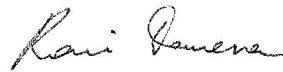

Ravi Damera, P.E., BCEE
Senior Project Manager



Gary Grinstead, P.G.
Operations Manager

cc: Ms. Fariba Mahvi, Pepco

Attachments:

Table 1
Figures 1 through 7
Attachment A

Tables

**Table 1 - Proposed Monitoring Wells
RI/FS Addendum #1
Pepco Benning Road Facility**

Nested Well	Location	Well ID	Total Depth (ft bgs)	Screen Interval (ft bgs)	Rationale	Previous Detections
MW-01	Southwest corner of western boundary	MW-01-A	30	5-30	Perimeter monitoring. Evaluate discharge to Anacostia River from upper water-bearing zone.	None
		MW-02-B	60	45-60	Perimeter monitoring. Evaluate discharge to Anacostia River from lower water-bearing zone.	None
MW-02	Between DP-01 and DP-02	MW-02-A	30	5-30	Perimeter monitoring. Evaluate discharge to Anacostia River from upper water-bearing zone.	None
		MW-02-B	60	45-60	Perimeter monitoring. Evaluate discharge to Anacostia River from lower water-bearing zone.	None
MW-03	North of DP-36	MW-03-A	30	5-30	Perimeter monitoring. Evaluate discharge to Anacostia River from upper water-bearing zone.	None
		MW-03-B	60	45-60	Perimeter monitoring. Evaluate discharge to Anacostia River from lower water-bearing zone.	None
MW-04	Northwest corner of western boundary	MW-04-A	30	5-30	Perimeter monitoring. Evaluate discharge to Anacostia River from upper water-bearing zone.	None
		MW-04-B	60	45-60	Perimeter monitoring. Evaluate discharge to Anacostia River from lower water-bearing zone.	None
MW-05	DP-03	MW-05-A	18	8-18	Perimeter monitoring, upper water-bearing zone.	None
		MW-05-B	60	45-60	Evaluate detection of PCBs in lower water-bearing zone.	0.011 ppb PCBs at 47-52' bgs in DP-03
MW-06	DP-37	MW-06-A	18	8-18	Evaluate PAHs and PCBs detections in upper water-bearing zone in DP-37.	0.013 ppb PCBs and 4.0 ppb PAHs at 13-18' in DP-37
		MW-06-B	40	25-40	Evaluate PAHs in lower water-bearing zone.	2.4 ppb PAHs at 25-30' bgs in DP-37
MW-07	DP-41	MW-07-A	25	15-25	Evaluate dioxins/furans detection in upper water-bearing zone in nearby DP-08.	37.2 ppb Dioxins/ Furans at 15-25' bgs in DP-08
		MW-07-B	54	39-54	Evaluate PCBs in lower water-bearing zone in DP-41.	0.039 ppb PCBs at 39-44' bgs in DP-41
MW-08	DP-05	MW-08-A	20	5-20	Perimeter monitoring. Evaluate PCBs detection in DP-05 in upper water-bearing zone.	0.15 ppb PCBs at 14-19' bgs in DP-05
		MW-08-B	60	45-60	Evaluate PCBs in lower water-bearing zone.	No deep sample collected.
MW-09	DP-09	MW-09-A	30	15-30	Perimeter monitoring. Evaluate PCE detection in DP-09 in upper water-bearing zone.	160 ppb PCE at 25-30' bgs in DP-09
		MW-09-B	70	60-70	Evaluate PCE in lower water-bearing zone.	No deep sample collected.
MW-10	DP-10	MW-10-A	20	10-20	Evaluate pesticide detection in DP-10 in upper water-bearing zone.	0.0037 Heptachlor epoxide at 15-20' bgs in DP-10
		MW-10-B	50	40-50	Evaluate pesticide in lower water-bearing zone.	No deep sample collected.
MW-11	DP-13	MW-11-A	25	10-25	Perimeter monitoring, upper water-bearing zone.	None
		MW-11-B	50	40-50	Perimeter monitoring, lower water-bearing zone.	None
MW-12	Southeast of DP-19	MW-12-A	35	10-35	Perimeter monitoring, upper water-bearing zone.	None
		MW-12-B	60	45-60	Perimeter monitoring, lower water-bearing zone.	None
MW-13	DP-17	MW-13-A	18	8-18	Evaluate dioxins/furans detection in DP-17 in upper water-bearing zone.	3 dioxin/ furan compounds above PSL at 13-18' bgs in DP-17
		MW-13-B	50	35-50	Evaluate dioxins/furans in lower water-bearing zone.	No deep sample collected.
MW-14	DP-24	MW-14-A	30	10-30	Perimeter monitoring, upper water-bearing zone.	None
		MW-14-B	55	40-55	Perimeter monitoring, lower water-bearing zone.	None
MW-15	DP-34	MW-15-A	20	5-20	Perimeter monitoring, upper water-bearing zone.	None
		MW-15-B	58	46-58	Perimeter monitoring, lower water-bearing zone.	None

Notes:

ft bgs - feet below ground surface

MW - Monitoring Well

DP - Direct Push soil boring

PAHs - polycyclic aromatic hydrocarbons

PCBs - polychlorinated biphenyls

PCE - tetrachloroethylene

Direct push soil boring and monitoring well locations are depicted on Figure 2.

Exact well locations and screened intervals are subject to change based on field conditions.

Figures

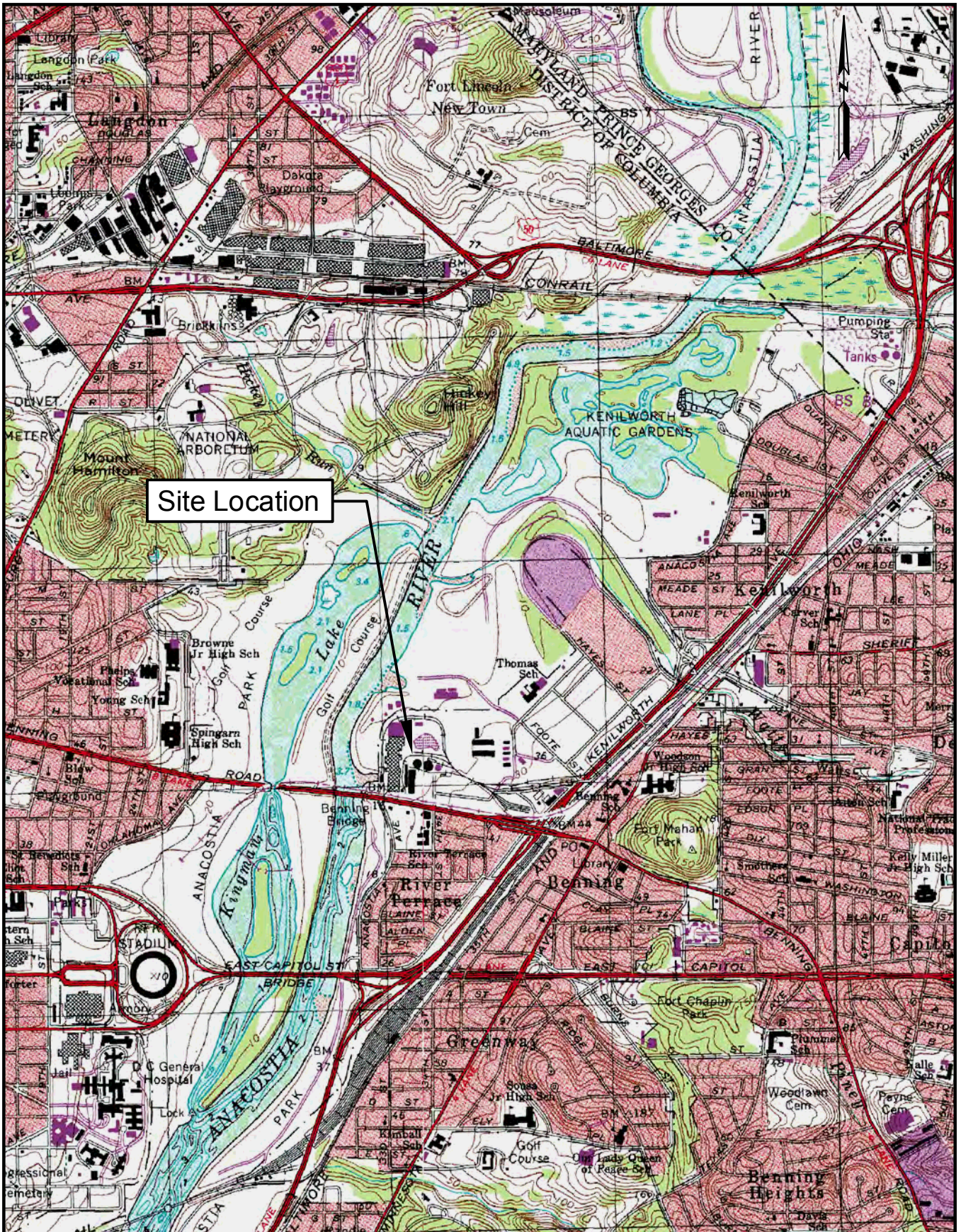

Site Location



Source:
USGS 7.5 Minute Topographic Map
Washington East Quadrangle

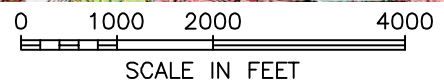

Benning Road Facility RI/FS Project
3400 Benning Rd., NE
Washington, DC 20019

Site Location Map

DATE: 07/09/2012

DRAWN BY: LAD

CHECKED BY: RD

FIGURE 1

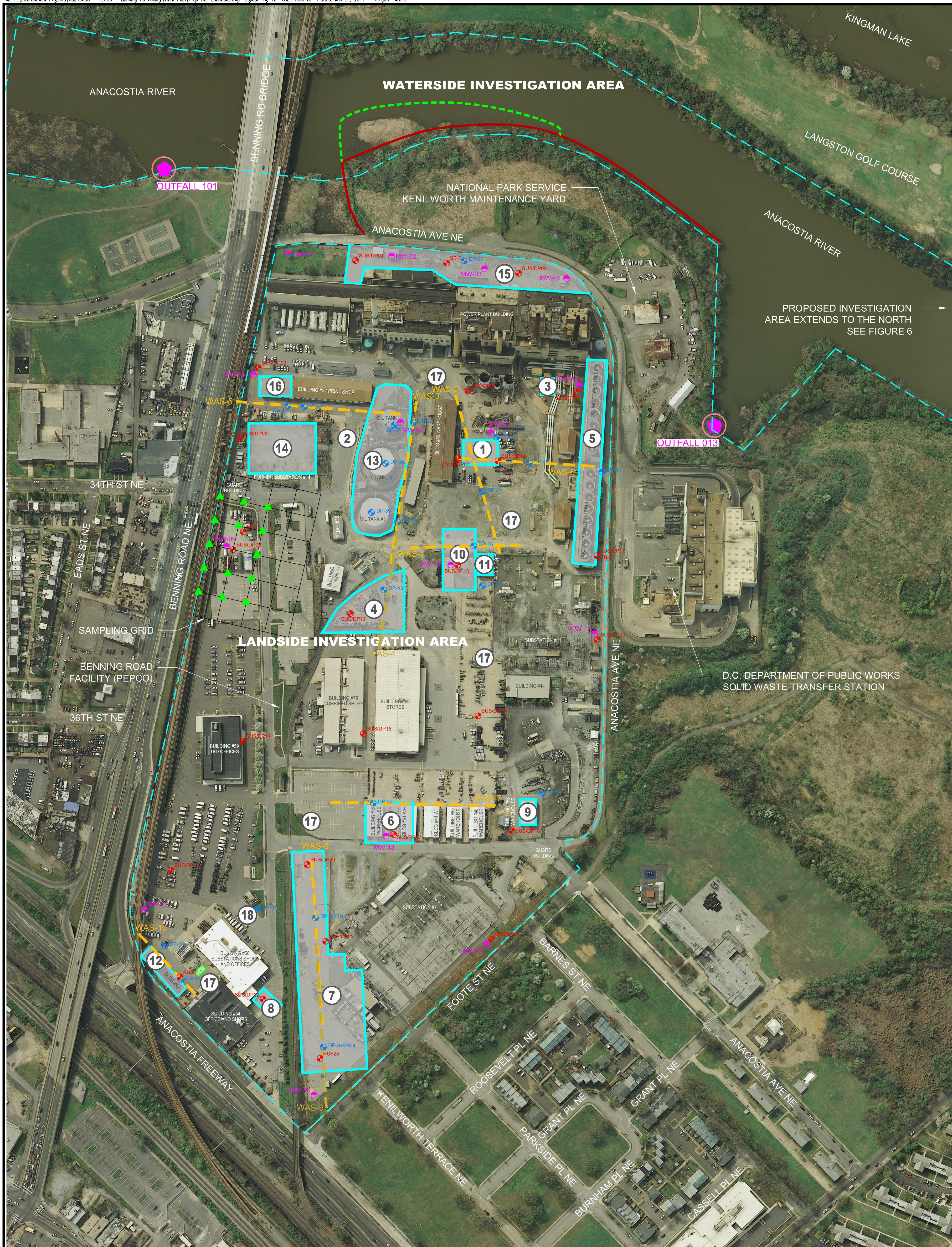

PROPOSED INVESTIGATION AREA EXTENDS TO THE NORTH SEE FIGURE 6

D.C. DEPARTMENT OF PUBLIC WORKS SOLID WASTE TRANSFER STATION

- LEGEND:**
- PROPOSED MONITORING WELL LOCATION
 - ▲ PROPOSED PCE SAMPLE LOCATION
 - SURFACE AND SUBSURFACE SOIL SAMPLE LOCATION
 - DIRECT PUSH SAMPLE LOCATION
 - ELECTRICAL RESISTIVE IMAGING (ERI) TRANSECT
 - 18 TARGET AREA # - CORRESPONDS TO DESCRIPTION IN TABLE 2
 - TARGET AREA
 - INVESTIGATION AREA
 - APPROXIMATE FORMER CONSTRUCTED WETLANDS BOUNDARY
 - APPROXIMATE LOCATION OF SEA WALL
 - 15,000 GALLON TRANSFORMER OIL UST

- TARGET AREA KEY:**
- | | |
|---|--|
| ① FORMER SLUDGE DEWATERING AREA | ⑩ RED TAG STORAGE AREA |
| ② BENNING FUELING ISLAND | ⑪ BUILDING #68 (PCB BUILDING) |
| ③ FORMER 15,000 GALLON No. 2 FUEL OIL UST | ⑫ BUILDING #57 |
| ④ 2003 SALVAGE YARD INVESTIGATION | ⑬ BULK STORAGE ASTS WITH LOADING RACK, 550 GALLON FUEL OIL UST AND 2,000 GALLON USED OIL UST |
| ⑤ 1995 CLEANUP AREA | ⑭ FORMER RAILROAD SWITCHYARD |
| ⑥ 1991 CLEANUP AREA | ⑮ GENERATING STATION TRANSFORMERS |
| ⑦ 1988 PARKING LOT CLEANUP AREA | ⑯ PRINT SHOP |
| ⑧ 1985 EXCAVATION AREA | ⑰ STORM DRAIN SYSTEM |
| ⑨ GREEN TAG STORAGE AREA | ⑱ KENILWORTH FUELING ISLAND |

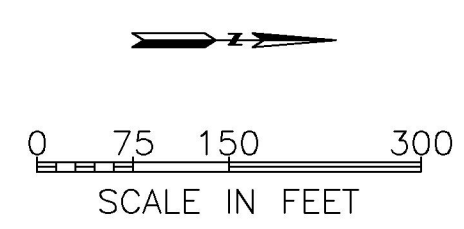

*NOTE:
MW-09 LOCATION IS APPROXIMATE. EXACT LOCATION WILL BE DETERMINED BASED ON PCE DELINEATION SAMPLING RESULTS.



Benning Road Facility RI/FS Project
3400 Benning Rd., NE
Washington, DC 20019

Proposed Monitoring Well Locations

DATE: 01/30/2014

DRAWN BY: LAD

CHECKED BY: RD

FIGURE 2

A
East

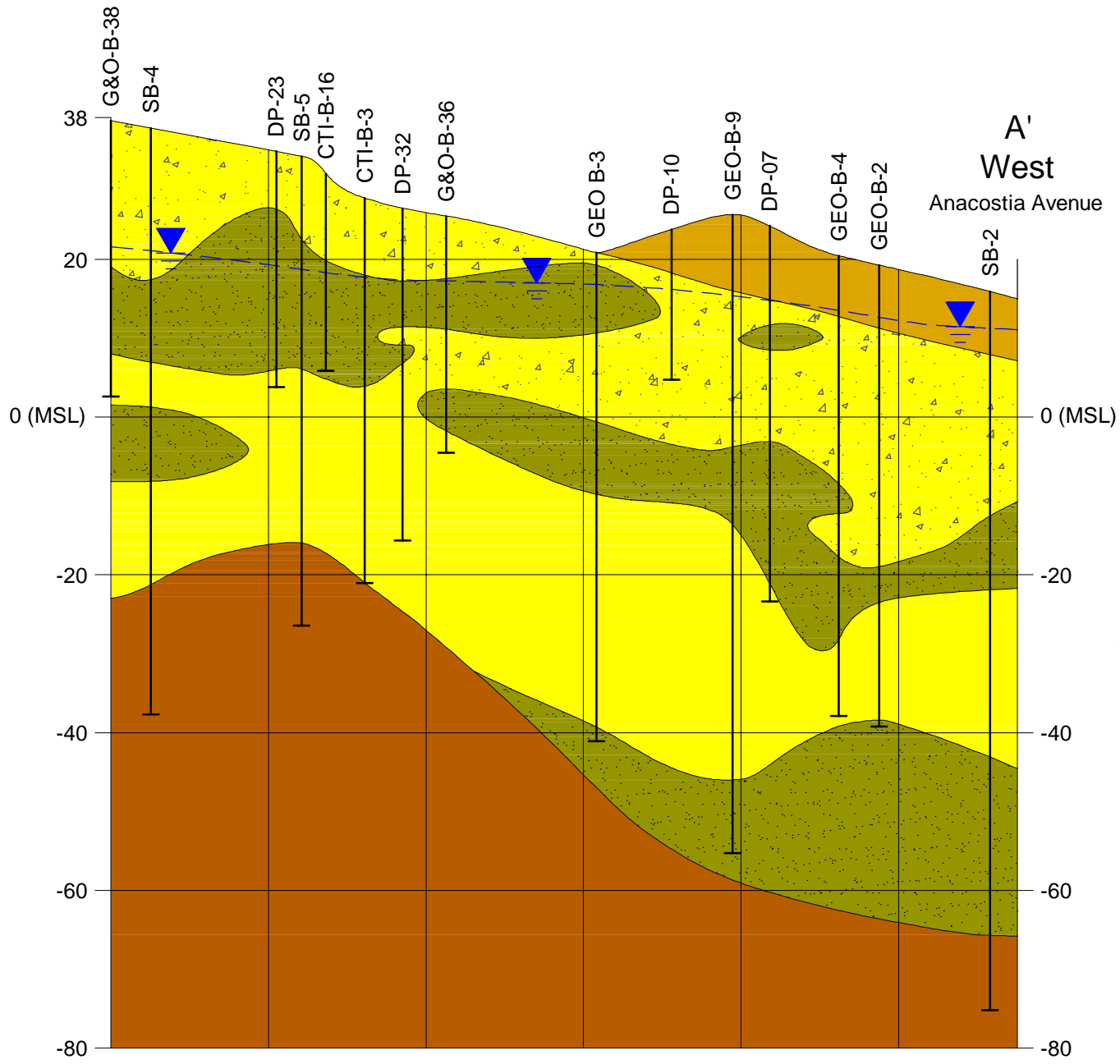

A'
West
Anacostia Avenue

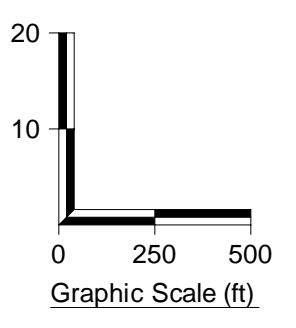

B
South

Cross Section A-A'

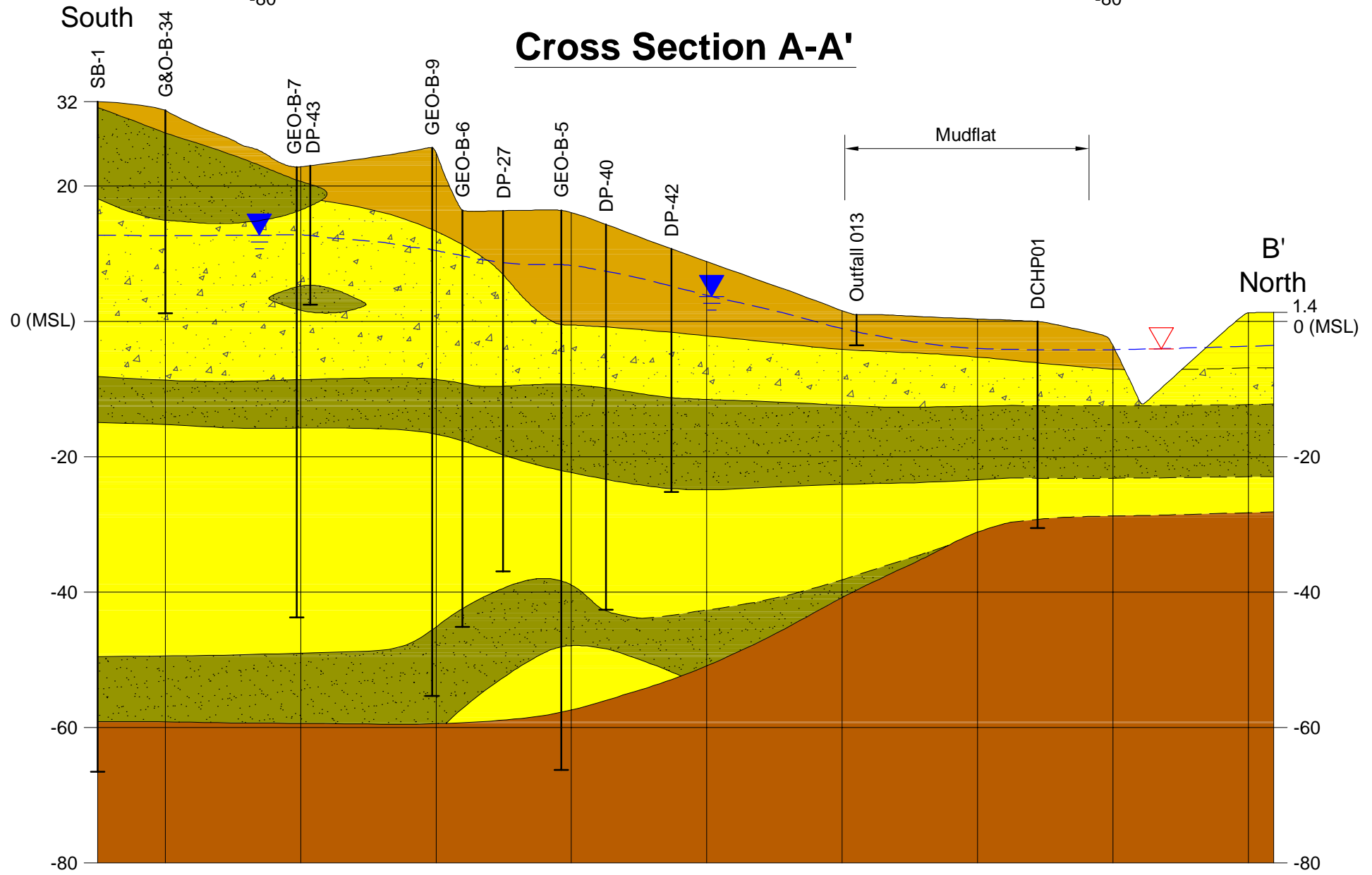

B'
North
1.4
0 (MSL)

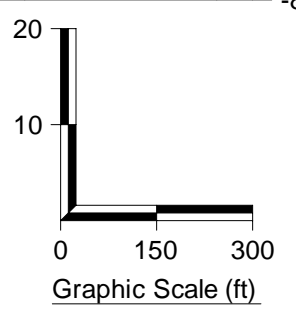

Cross Section B-B'

Legend:

- Boring Location And ID
- Inferred Lithology
- Alluvium/Fill
- Sand
- Sand/Gravel
- Clay, Silt, and Sand Intermixed
- Arundel Clay
- MSL Mean Sea Level
- Depth To Water (Encountered during drilling.)
- Stream Gauge (Taken at low tide from USGS Station 01651750)
- Approximate Water Table



Benning Road Facility RI/FS Project 3400 Benning Rd., NE Washington, DC 20019		Site-Wide Geologic Cross Sections	
DATE: 02/10/2014	DRAWN BY: LAD	CHECKED BY: RD	FIGURE 3

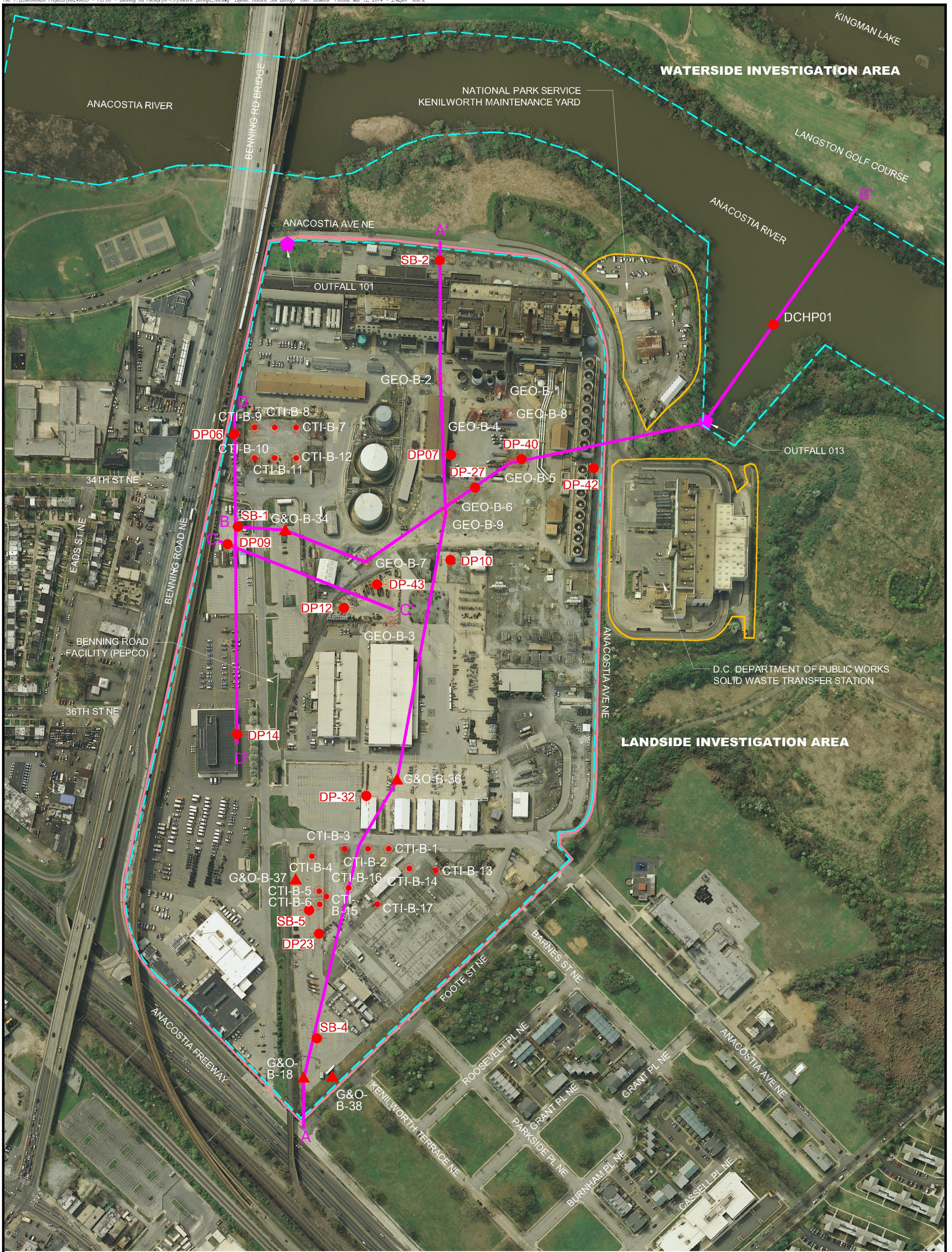

- LEGEND:**
- ⊗ APPROXIMATE LOCATION OF SOIL BORING INSTALLED BY GEOMATRIX, INC. IN 1988
 - APPROXIMATE LOCATION OF SOIL BORING INSTALLED BY CTI CONSULTANTS, INC. IN 2009
 - ▲ APPROXIMATE LOCATION OF SOIL BORING INSTALLED BY GREENHOUSE & O'MARA, INC. IN 2009
 - ⊙ USGS SOIL BORING DCHP01 INSTALLED IN 2002
 - ◆ LOCATION OF SOIL BORING INSTALLED BY AECOM IN 2013
 - PROPOSED INVESTIGATION AREA
 - BENNING ROAD FACILITY PROPERTY BOUNDARY
 - PROPERTY BOUNDARY
 - A-A LINE OF CROSS-SECTION



Benning Road Facility RI/FS Project 3400 Benning Rd., NE Washington, DC 20019		HISTORICAL SOIL BORINGS AND CROSS-SECTION LOCATION MAP
DATE: 03/04/2014	DRAWN BY: LAD	CHECKED BY: RD
		FIGURE 4

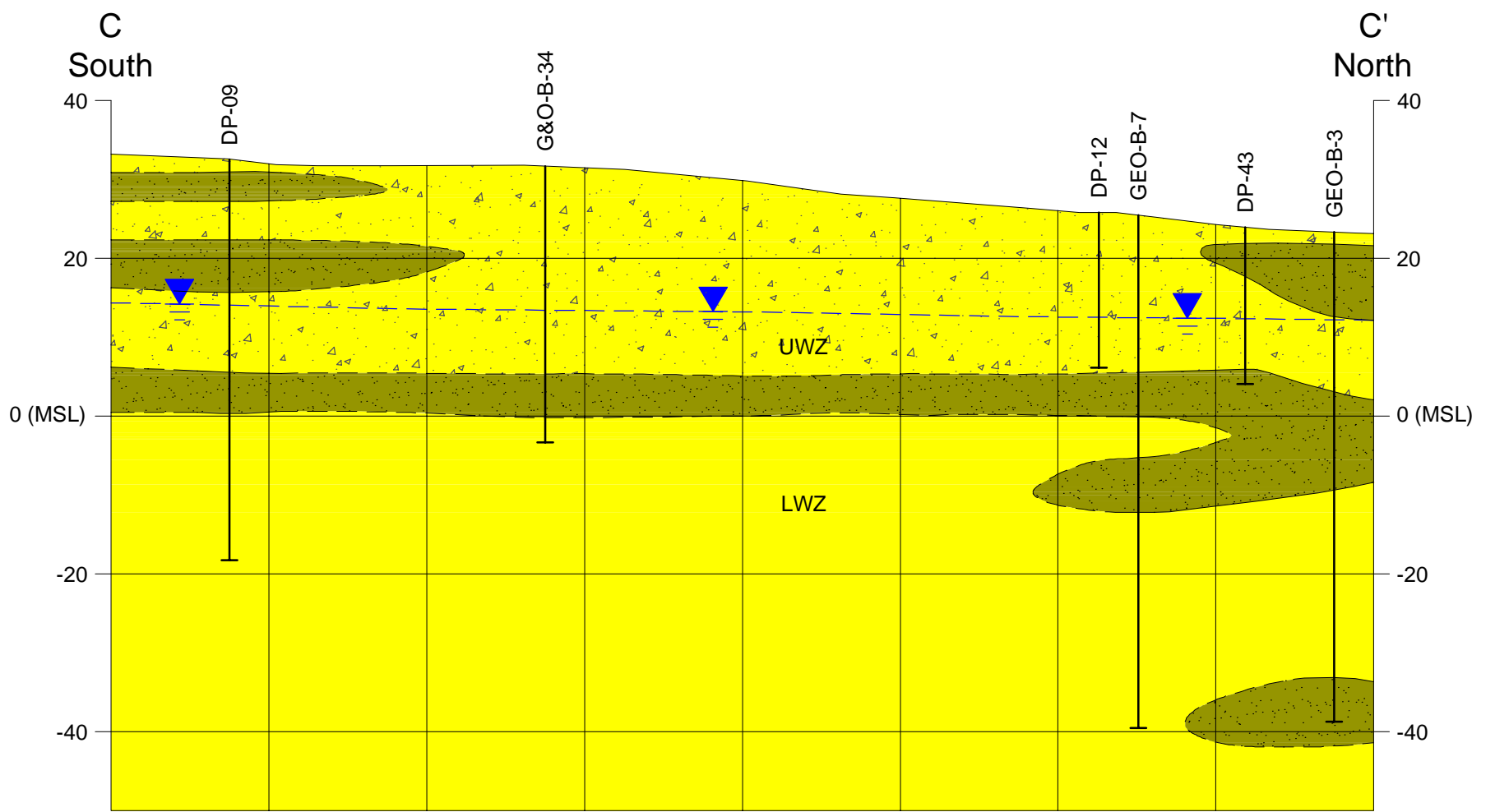

Cross Section C-C'

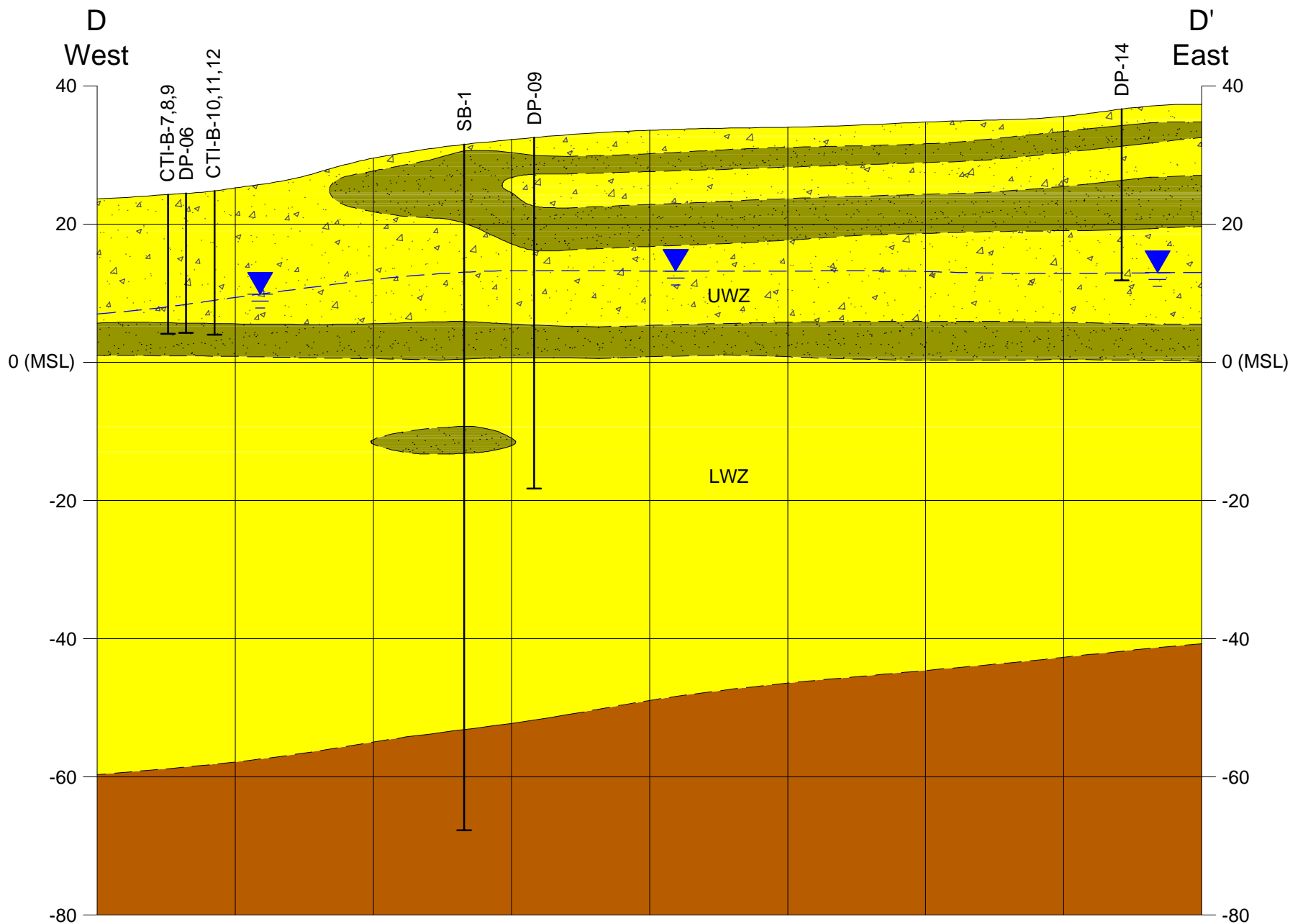
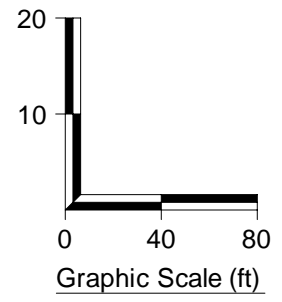

Cross Section D-D'

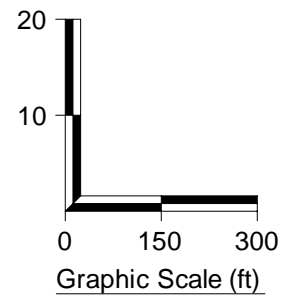

Legend:

- Boring Location And ID
- Inferred Lithology
- Sand
- MSL Mean Sea Level
- Sand/Gravel
- Depth To Water (Encountered during drilling.)
- Clay, Silt, and Sand Intermixed
- Approximate Water Table
- Arundel Clay
- UWZ Upper Water-Bearing Zone
- LWZ Lower Water-Bearing Zone



Benning Road Facility RI/FS Project
3400 Benning Rd., NE
Washington, DC 20019

Geologic Cross Sections
Within the PCE Investigation Area

DATE: 03/04/2014

DRAWN BY: LAD

CHECKED BY: RD

FIGURE 5

FIGURE 6 - MONITORING WELL SCHEMATIC

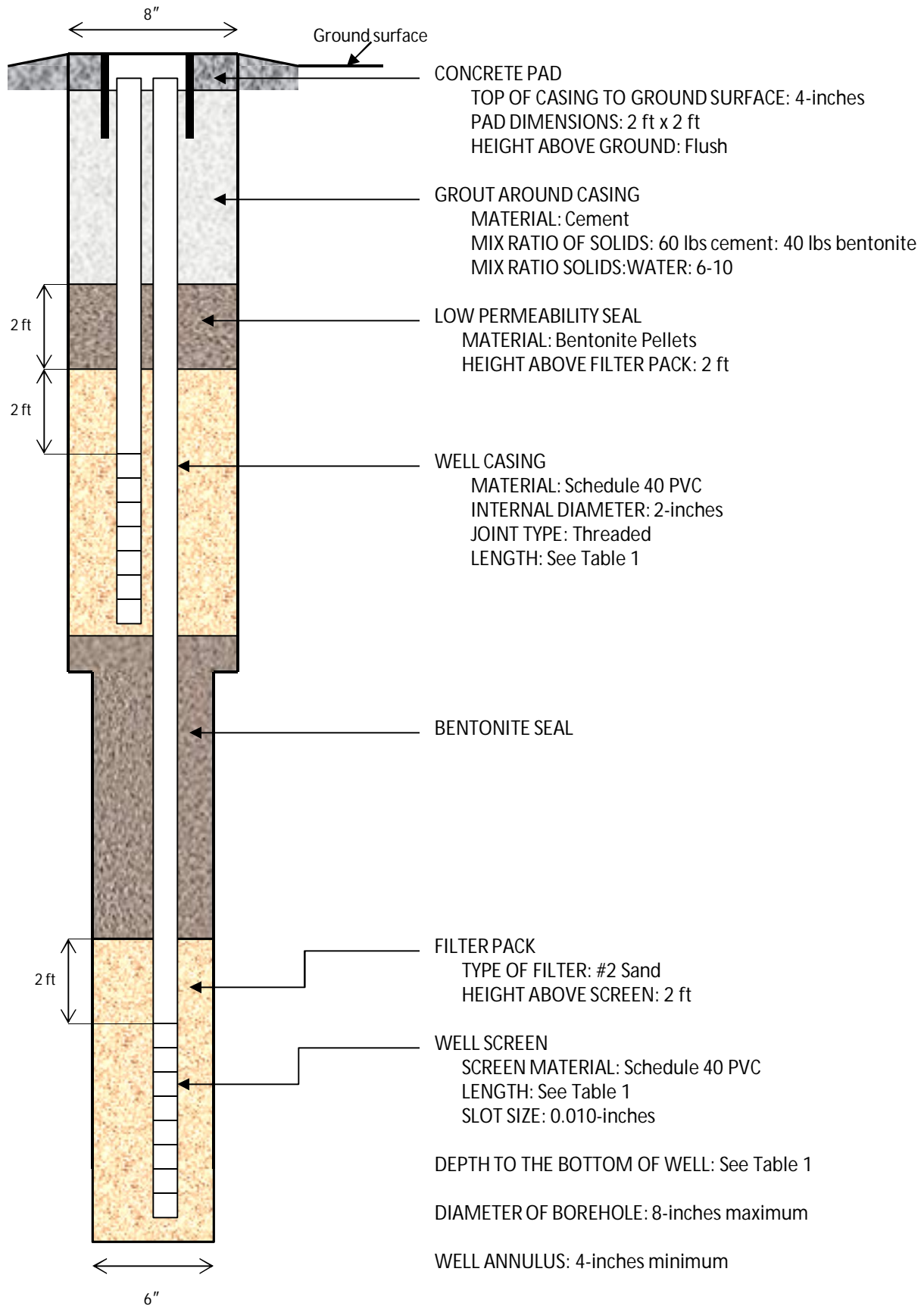
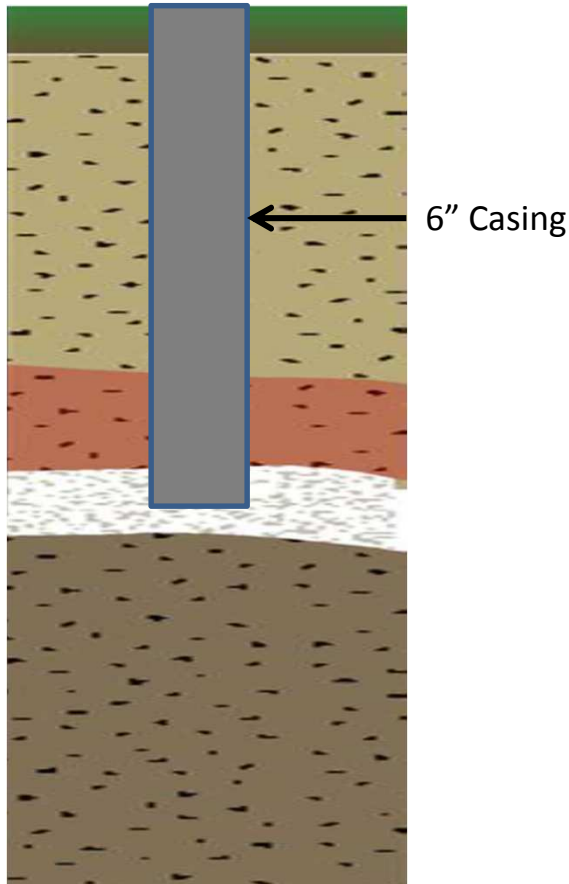

FIGURE 7 - NESTED WELL CONSTRUCTION STEPS

Step 1.

Advance 6" Sonic casing and coring system to depth of confining layer (core barrel removed.)



Step 2.

Advance 8" Sonic override casing to depth of confining layer.

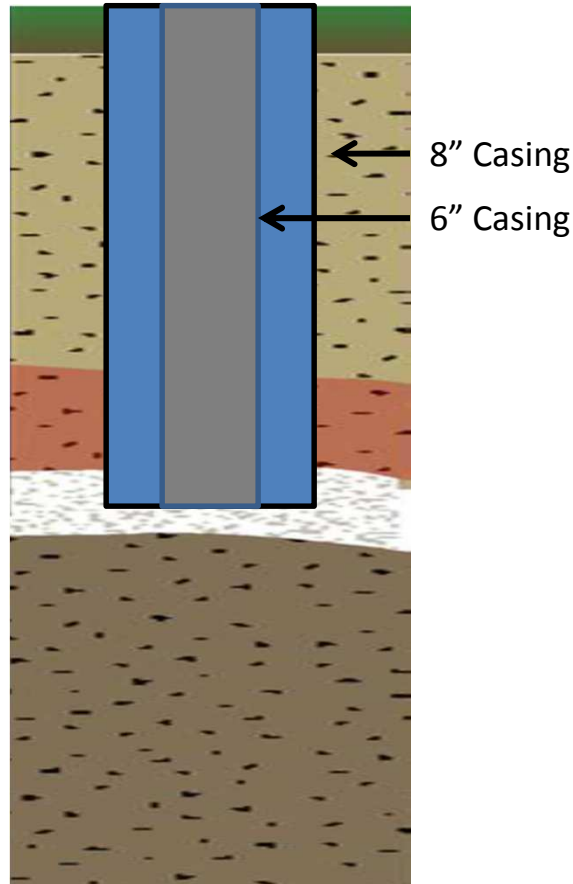

Step 3.

Continue to advance 6" Sonic casing and coring system to total depth of the borehole. Leaving 8" in place to temporarily seal off the surface.

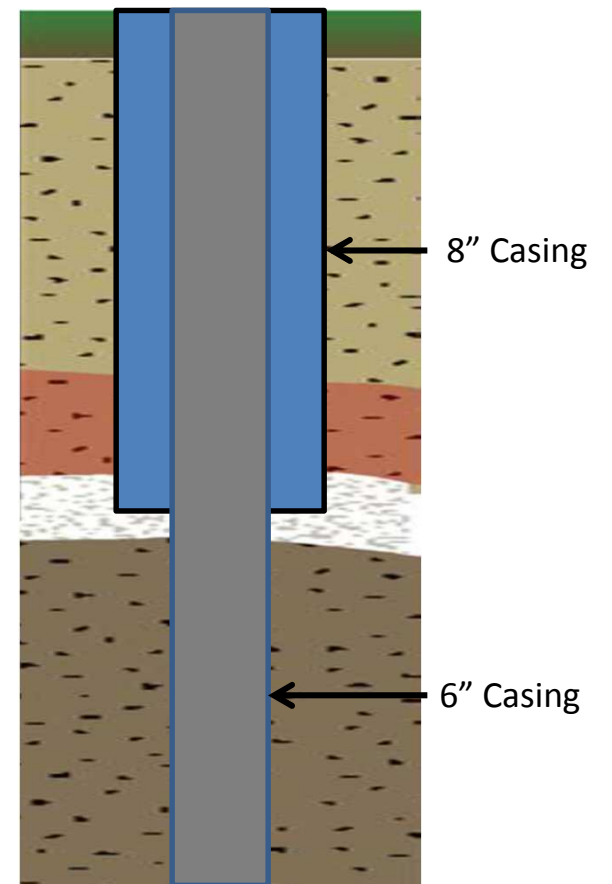
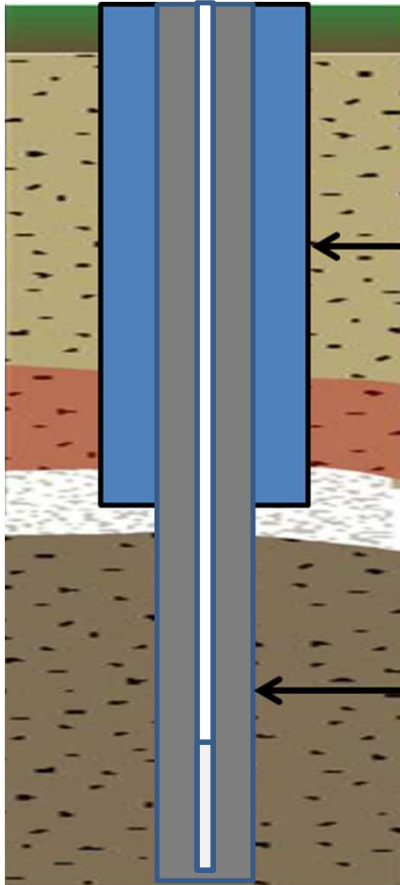

FIGURE 7 - NESTED WELL CONSTRUCTION STEPS

Step 4

Lower 2" well and screen to the deepest setting.



Step 5

Install filter pack around well screen and begin installing bentonite chip seal as the 6" casing is vibrated and extracted.

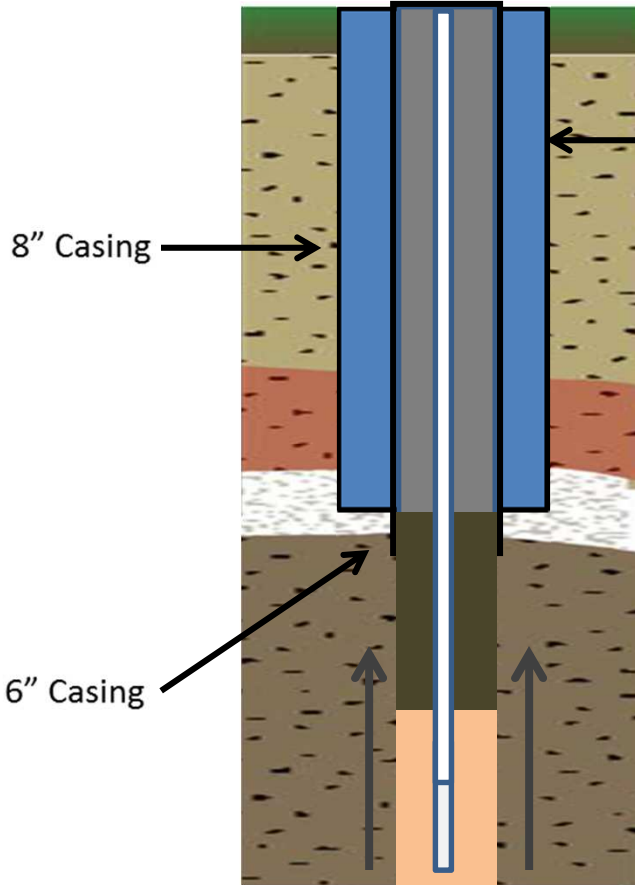

Step 6

Lower 2" well and screen to the shallow setting. Install filter pack and bentonite chip seal as 8" Sonic casing is vibrated and extracted. Continue extracting 8" casing as surface grout seal is emplaced.

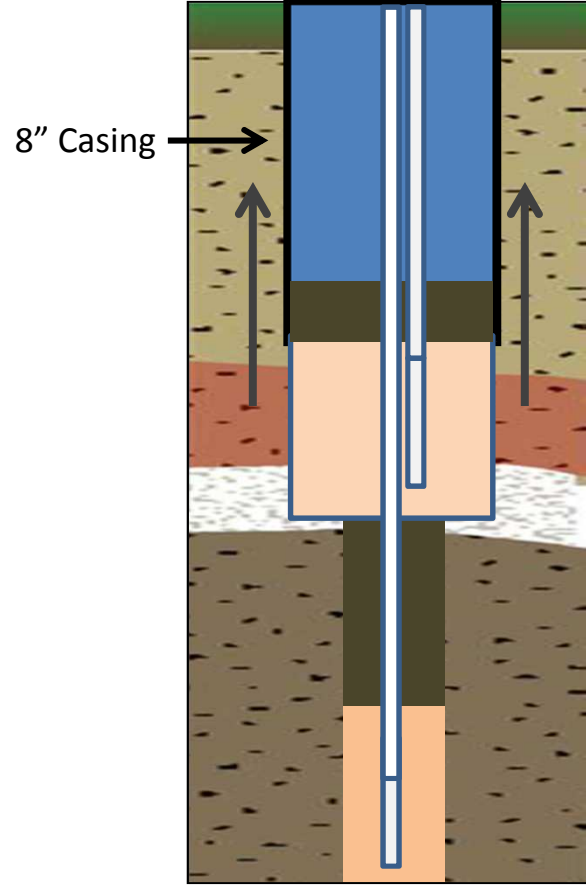

Attachment A
HydraSleeve SOP and Field
Manual

HYDRASleeve™

Simple by Design

US Patent No. 6,481,300; No. 6,837,120 others pending

Standard Operating Procedure: Sampling Ground Water with a HydraSleeve

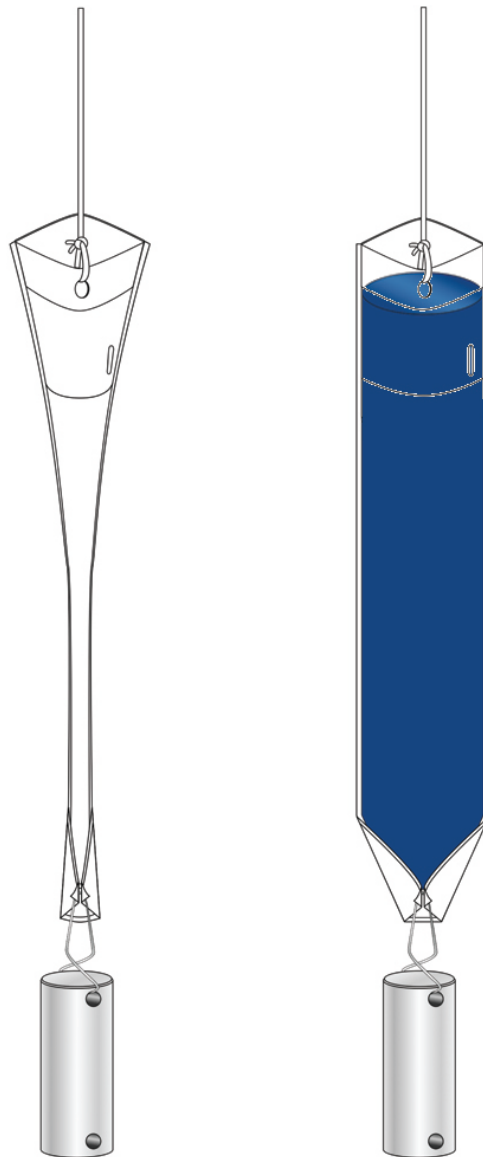

This Guide should be used in addition to field manuals appropriate to sampling device (i.e., HydraSleeve or Super Sleeve).

Find the appropriate field manual on the HydraSleeve website at <http://www.hydrasleeve.com>.

For more information about the HydraSleeve, or if you have questions, contact:
GeoInsight, 2007 Glass Road, Las Cruces, NM 88005, 1-800-996-2225,
info@hydrasleeve.com.

Copyright, GeoInsight.

Table of Contents

Introduction.....	1
Applications of the HydraSleeve	1
Description of the HydraSleeve	3
Selecting the HydraSleeve Size to Meet Site-Specific Sampling Objectives.....	4
HydraSleeve Deployment	5
Information Required Before Deploying a HydraSleeve.....	5
HydraSleeve Placement	6
Procedures for Sampling with the HydraSleeve	8
Measurement of Field Indicator Parameters	11
Alternate Deployment Strategies	11
Post-Sampling Activities	14
References.....	15

Introduction

The HydraSleeve is classified as a no-purge (passive) grab sampling device, meaning that it is used to collect ground-water samples directly from the screened interval of a well without having to purge the well prior to sample collection. When it is used as described in this Standard Operating Procedure (SOP), the HydraSleeve causes no drawdown in the well (until the sample is withdrawn from the water column) and only minimal disturbance of the water column, because it has a very thin cross section and it displaces very little water (<100 ml) during deployment in the well. The HydraSleeve collects a sample from within the screen only, and it excludes water from any other part of the water column in the well through the use of a self-sealing check valve at the top of the sampler. It is a single-use (disposable) sampler that is not intended for reuse, so there are no decontamination requirements for the sampler itself.

The use of no-purge sampling as a means of collecting representative ground-water samples depends on the natural movement of ground water (under ambient hydraulic head) from the formation adjacent to the well screen through the screen. Robin and Gillham (1987) demonstrated the existence of a dynamic equilibrium between the water in a formation and the water in a well screen installed in that formation, which results in formation-quality water being available in the well screen for sampling at all times. No-purge sampling devices like the HydraSleeve collect this formation-quality water as the sample, under undisturbed (non-pumping) natural flow conditions. Samples collected in this manner generally provide more conservative (i.e., higher concentration) values than samples collected using well-volume purging, and values equivalent to samples collected using low-flow purging and sampling (Parsons, 2005).

Applications of the HydraSleeve

The HydraSleeve can be used to collect representative samples of ground water for all analytes (volatile organic compounds [VOCs], semi-volatile organic compounds [SVOCs], common metals, trace metals, major cations and anions, dissolved gases, total dissolved solids, radionuclides, pesticides, PCBs, explosive compounds, and all other analytical parameters). Designs are available to collect samples from wells from 1" inside diameter and larger. The HydraSleeve can collect samples from wells of any yield, but it is especially well-suited to collecting samples from low-yield wells, where other sampling methods can't be used reliably because their use results in dewatering of the well screen and alteration of sample chemistry (McAlary and Barker, 1987).

The HydraSleeve can collect samples from wells of any depth, and it can be used for single-event sampling or long-term ground-water monitoring programs. Because of its thin cross section and flexible construction, it can be used in narrow, constricted or damaged wells where rigid sampling devices may not fit. Using multiple HydraSleeves deployed in series along a single suspension line or tether, it is also possible to conduct in-well vertical profiling in wells in which contaminant concentrations are thought to be stratified.

As with all groundwater sampling devices, HydraSleeves should not be used to collect groundwater samples from wells in which separate (non-aqueous) phase hydrocarbons (i.e., gasoline, diesel fuel or jet fuel) are present because of the possibility of incorporating some of the separate-phase hydrocarbon into the sample.

Description of the HydraSleeve

The HydraSleeve (Figure 1) consists of the following basic components:

- A suspension line or tether (A.), attached to the spring clip or directly to the top of the sleeve to deploy the device into and recover the device from the well. Tethers with depth indicators marked in 1-foot intervals are available from the manufacturer.
- A long, flexible, 4-mil thick lay-flat polyethylene sample sleeve (C.) sealed at the bottom (this is the sample chamber), which comes in different sizes, as discussed below with a self-sealing reed-type flexible polyethylene check valve built into the top of the sleeve (B.) to prevent water from entering or exiting the sampler except during sample acquisition.
- A reusable stainless-steel weight with clip (D.), which is attached to the bottom of the sleeve to carry it down the well to its intended depth in the water column. Bottom weights available from the manufacturer are 0.75" OD and are available in three sizes: 5 oz. (2.5" long); 8 oz. (4" long); and 16 oz. (8" long). In lieu of a bottom weight, an optional top weight may be attached to the top of the HydraSleeve to carry it to depth and to compress it at the bottom of the well (not shown in Figure 1);
- A discharge tube that is used to puncture the HydraSleeve after it is recovered from the well so the sample can be decanted into sample bottles (not shown).
- Just above the self-sealing check valve at the top of the sleeve are two holes which provide attachment points for the spring clip and/or suspension line or tether. At the bottom of the sample sleeve are two holes which provide attachment points for the weight clip and weight.

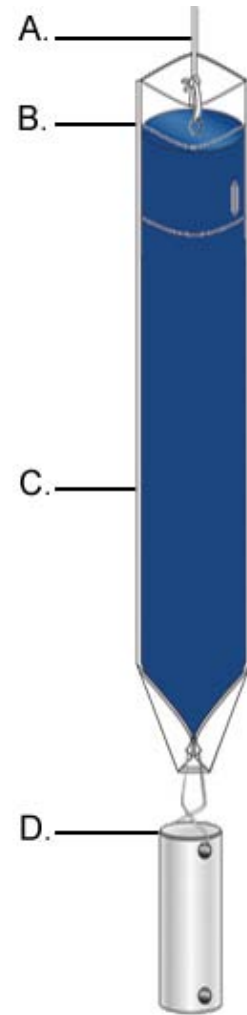

Figure 1. HydraSleeve components.

Note: The sample sleeve and the discharge tube are designed for one-time use and are disposable. The spring clip, weight and weight clip may be reused after thorough cleaning. Suspension cord is generally disposed after one use although, if it is dedicated to the well, it may be reused at the discretion of the sampling personnel.

Selecting the HydraSleeve Size to Meet Site-Specific Sampling Objectives

It is important to understand that each HydraSleeve is able to collect a finite volume of sample because, after the HydraSleeve is deployed, you only get one chance to collect an undisturbed sample. Thus, the volume of sample required to meet your site-specific sampling and analytical requirements will dictate the size of HydraSleeve you need to meet these requirements.

The volume of sample collected by the HydraSleeve varies with the diameter and length of the HydraSleeve. Dimensions and volumes of available HydraSleeve models are detailed in Table 1.

Table 1. Dimensions and volumes of HydraSleeve models.

Diameter	Volume	Length	Lay-Flat Width	Filled Dia.
<i>2-Inch HydraSleeves</i>				
Standard 625-ml HydraSleeve	625 ml	< 30"	2.5"	1.4"
Standard 1-Liter HydraSleeve	1 Liter	38"	3"	1.9"
1-Liter HydraSleeve SS	1 Liter	36"	3"	1.9"
2-Liter HydraSleeve SS	2 Liters	60"	3"	1.9"
<i>4-Inch HydraSleeves</i>				
Standard 1.6-Liter HydraSleeve	1.6 Liters	30"	3.8"	2.3"
Custom 2-Liter HydraSleeve	2 Liters	36"	4"	2.7"

HydraSleeves can be custom-fabricated by the manufacturer in varying diameters and lengths to meet specific volume requirements. HydraSleeves can also be deployed in series (i.e., multiple HydraSleeves attached to one tether) to collect additional sample to meet specific volume requirements, as described below.

If you have questions regarding the availability of sufficient volume of sample to satisfy laboratory requirements for analysis, it is recommended that you contact the laboratory to discuss the minimum volumes needed for each suite of analytes. Laboratories often require only 10% to 25% of the volume they specify to complete analysis for specific suites of analytes, so they can often work with much smaller sample volumes that can easily be supplied by a HydraSleeve.

HydraSleeve Deployment

Information Required Before Deploying a HydraSleeve

Before installing a HydraSleeve in any well, you will need to know the following:

- The inside diameter of the well
- The length of the well screen
- The water level in the well
- The position of the well screen in the well
- The total depth of the well

The inside diameter of the well is used to determine the appropriate HydraSleeve diameter for use in the well. The other information is used to determine the proper placement of the HydraSleeve in the well to collect a representative sample from the screen (see HydraSleeve Placement, below), and to determine the appropriate length of tether to attach to the HydraSleeve to deploy it at the appropriate position in the well.

Most of this information (with the exception of the water level) should be available from the well log; if not, it will have to be collected by some other means. The inside diameter of the well can be measured at the top of the well casing, and the total depth of the well can be measured by sounding the bottom of the well with a weighted tape. The position and length of the well screen may have to be determined using a down-hole camera if a well log is not available. The water level in the well can be measured using any commonly available water-level gauge.

HydraSleeve Placement

The HydraSleeve is designed to collect a sample directly from the well screen, and it fills by pulling it up through the screen a distance equivalent to 1 to 1.5 times its length. This upward motion causes the top check valve to open, which allows the device to fill. To optimize sample recovery, it is recommended that the HydraSleeve be placed in the well so that the bottom weight rests on the bottom of the well and the top of the HydraSleeve is as close to the bottom of the well screen as possible. This should allow the sampler to fill before the top of the device reaches the top of the screen as it is pulled up through the water column, and ensure that only water from the screen is collected as the sample. In short-screen wells, or wells with a short water column, it may be necessary to use a top-weight on the HydraSleeve to compress it in the bottom of the well so that, when it is recovered, it has room to fill before it reaches the top of the screen.

Example

2" ID PVC well, 50' total depth, 10' screen at the bottom of the well, with water level above the screen (the entire screen contains water).

Correct Placement (figure 2): Using a standard HydraSleeve for a 2" well (2.6" flat width/1.5" filled OD x 30" long, 650 ml volume), deploy the sampler so the weight (an 8 oz., 4"-long weight with a 2"-long clip) rests at the bottom of the well. The top of the sleeve is thus set at about 36" above the bottom of the well. When the sampler is recovered, it will be pulled upward approximately 30" to 45" before it is filled; therefore, it is full (and the top check valve closes) at approximately 66" (5 ½ feet) to 81" (6 ¾ feet) above the bottom of the well, which is well before the sampler reaches the top of the screen. In this example, only water from the screen is collected as a sample.

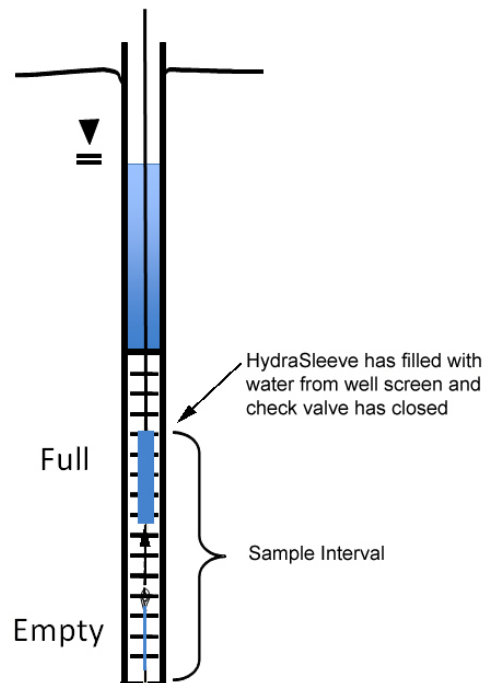

Figure 2. Correct placement of HydraSleeve.

Incorrect Placement (figure 3): If the well screen in this example was only 5' long, and the HydraSleeve was placed as above, it would not fill before the top of the device reached the top of the well screen, so the sample would include water from above the screen, which may not have the same chemistry.

The solution? Deploy the HydraSleeve with a top weight, so that it is collapsed to within 6" to 9" of the bottom of the well. When the HydraSleeve is recovered, it will fill within 39" (3 ¼ feet) to 54" (4 ½ feet) above the bottom of the well, or just before the sampler reaches the top of the screen, so it collects only water from the screen as the sample.

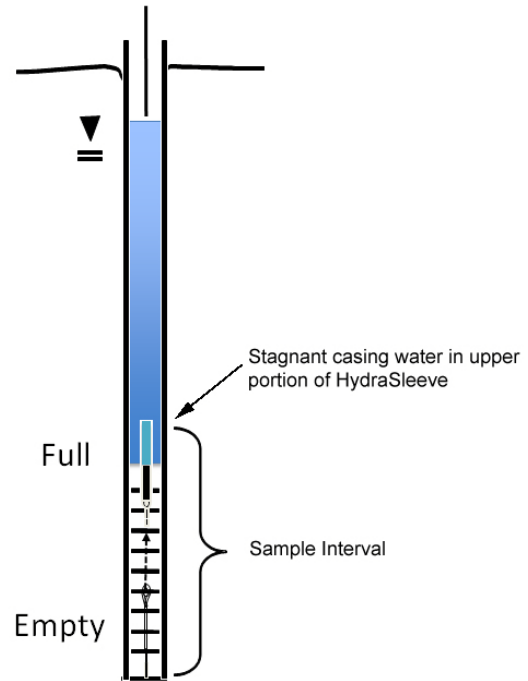

Figure 3. Incorrect placement of HydraSleeve.

This example illustrates one of many types of HydraSleeve placements. More complex placements are discussed in a later section.

Procedures for Sampling with the HydraSleeve

Collecting a ground-water sample with a HydraSleeve is a simple one-person operation.

Note: Before deploying the HydraSleeve in the well, collect the depth-to-water measurement that you will use to determine the preferred position of the HydraSleeve in the well. This measurement may also be used with measurements from other wells to create a ground-water contour map. If necessary, also measure the depth to the bottom of the well to verify actual well depth to confirm your decision on placement of the HydraSleeve in the water column.

Measure the correct amount of tether needed to suspend the HydraSleeve in the well so that the weight will rest on the bottom of the well (or at your preferred position in the well). Make sure to account for the need to leave a few feet of tether at the top of the well to allow recovery of the sleeve

Note: Always wear sterile gloves when handling and discharging the HydraSleeve.

I. Assembling the HydraSleeve

1. Remove the HydraSleeve from its packaging, unfold it, and hold it by its top.
2. Crimp the top of the HydraSleeve by folding the hard polyethylene reinforcing strips at the holes.
3. Attach the spring clip to the holes to ensure that the top will remain open until the sampler is retrieved.
4. Attach the tether to the spring clip by tying a knot in the tether.

Note: Alternatively, attach the tether to one (NOT both) of the holes at the top of the Hydrasleeve by tying a knot in the tether.

5. Fold the flaps with the two holes at the bottom of the HydraSleeve together and slide the weight clip through the holes.
6. Attach a weight to the bottom of the weight clip to ensure that the HydraSleeve will descend to the bottom of the well.

II. Deploying the HydraSleeve

1. Using the tether, carefully lower the HydraSleeve to the bottom of the well, or to your preferred depth in the water column

During installation, hydrostatic pressure in the water column will keep the self-sealing check valve at the top of the HydraSleeve closed, and ensure that it retains its flat, empty profile for an indefinite period prior to recovery.

Note: Make sure that it is not pulled upward at any time during its descent. If the HydraSleeve is pulled upward at a rate greater than 0.5'/second at any time prior to recovery, the top check valve will open and water will enter the HydraSleeve prematurely.

2. Secure the tether at the top of the well by placing the well cap on the top of the well casing and over the tether.

Note: Alternatively, you can tie the tether to a hook on the bottom of the well cap (you will need to leave a few inches of slack in the line to avoid pulling the sampler up as the cap is removed at the next sampling event).

III. Equilibrating the Well

The equilibration time is the time it takes for conditions in the water column (primarily flow dynamics and contaminant distribution) to restabilize after vertical mixing occurs (caused by installation of a sampling device in the well).

- Situation: The HydraSleeve is deployed for the first time or for only one time in a well

The HydraSleeve is very thin in cross section and displaces very little water (<100 ml) during deployment so, unlike most other sampling devices, it does not disturb the water column to the point at which long equilibration times are necessary to ensure recovery of a representative sample.

In most cases, the HydraSleeve can be recovered immediately (with no equilibration time) or within a few hours. In regulatory jurisdictions that impose specific requirements for equilibration times prior to recovery of no-purge sampling devices, these requirements should be followed.

- Situation: The HydraSleeve is being deployed for recovery during a future sampling event

In periodic (i.e., quarterly or semi-annual) sampling programs, the sampler for the current sampling event can be recovered and a new sampler (for the next sampling event)

deployed immediately thereafter, so the new sampler remains in the well until the next sampling event.

Thus, a long equilibration time is ensured and, at the next sampling event, the sampler can be recovered immediately. This means that separate mobilizations, to deploy and then to recover the sampler, are not required. HydraSleeves can be left in a well for an indefinite period of time without concern.

IV. HydraSleeve Recovery and Sample Collection

1. Hold on to the tether while removing the well cap.
2. Secure the tether at the top of the well while maintaining tension on the tether (but without pulling the tether upwards)
3. Measure the water level in the well.
4. In one smooth motion, pull the tether up between 30” to 45” (36” to 54” for the longer HydraSleeve) at a rate of about 1’ per second (or faster).

The motion will open the top check valve and allow the HydraSleeve to fill (it should fill in about 1 to 1.5 times the length of the HydraSleeve). This is analogous to coring the water column in the well from the bottom up.

When the HydraSleeve is full, the top check valve will close. You should begin to feel the weight of the HydraSleeve on the tether and it will begin to displace water. The closed check valve prevents loss of sample and entry of water from zones above the well screen as the HydraSleeve is recovered.

5. Continue pulling the tether upward until the HydraSleeve is at the top of the well.
6. Decant and discard the small volume of water trapped in the Hydrasleeve above the check valve by turning the sleeve over.

V. Sample Collection

Note: Sample collection should be done immediately after the HydraSleeve has been brought to the surface to preserve sample integrity.

1. Remove the discharge tube from its sleeve.
2. Hold the HydraSleeve at the check valve.
3. Puncture the HydraSleeve just below the check valve with the pointed end of the discharge tube
4. Discharge water from the HydraSleeve into your sample containers.

Control the discharge from the HydraSleeve by either raising the bottom of the sleeve, by squeezing it like a tube of toothpaste, or both.

5. Continue filling sample containers until all are full.

Measurement of Field Indicator Parameters

Field indicator parameter measurement is generally done during well purging and sampling to confirm when parameters are stable and sampling can begin. Because no-purge sampling does not require purging, field indicator parameter measurement is not necessary for the purpose of confirming when purging is complete.

If field indicator parameter measurement is required to meet a specific non-purging regulatory requirement, it can be done by taking measurements from water within a HydraSleeve that is not used for collecting a sample to submit for laboratory analysis (i.e., a second HydraSleeve installed in conjunction with the primary sample collection HydraSleeve [see Multiple Sampler Deployment below]).

Alternate Deployment Strategies

Deployment in Wells with Limited Water Columns

For wells in which only a limited water column exists to be sampled, the HydraSleeve can be deployed with an optional top weight instead of a bottom weight, which collapses the HydraSleeve to a very short (approximately 6" to 9") length, and allows the HydraSleeve to fill in a water column only 36" to 45" in height.

Multiple Sampler Deployment

Multiple sampler deployment in a single well screen can accomplish two purposes:

- It can collect additional sample volume to satisfy site or laboratory-specific sample volume requirements.
- It can accommodate the need for collecting field indicator parameter measurements.
- It can be used to collect samples from multiple intervals in the screen to allow identification of possible contaminant stratification.

It is possible to use up to 3 standard 30” HydraSleeves deployed in series along a single tether to collect samples from a 10’ long well screen without collecting water from the interval above the screen.

The samplers must be attached to the tether at both the top and bottom of the sleeve. Attach the tether at the top with a stainless-steel clip (available from the manufacturer). Attach the tether at the bottom using a cable tie. The samplers must be attached as follows (figure 4):

- The first (attached to the tether as described above, with the weight at the bottom) at the bottom of the screen
- The second attached immediately above the first
- The third (attached the same as the second) immediately above the second

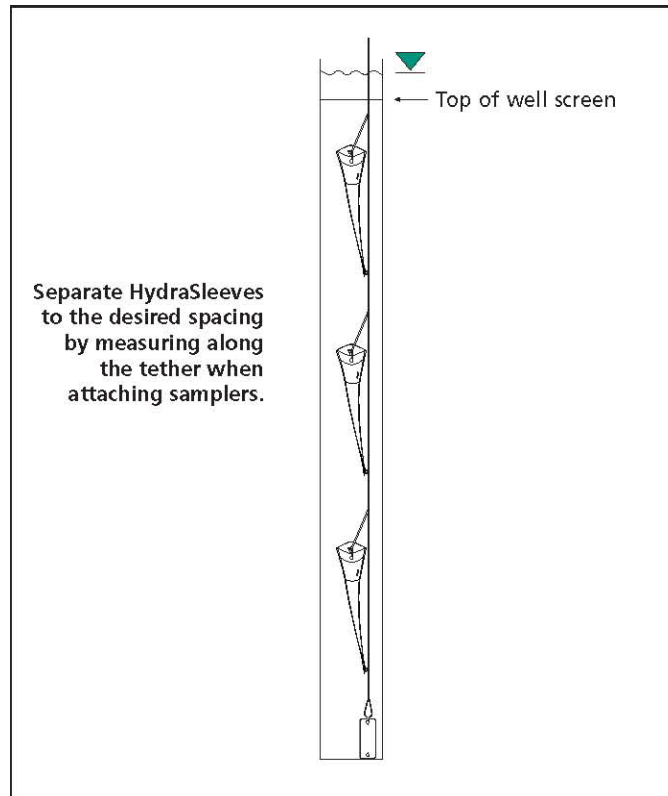

Figure 4. Multiple HydraSleeve deployment.

Alternately, the first sampler can be attached to the tether as described above, a second attached to the bottom of the first using a short length of tether (in place of the weight), and the third attached to the bottom of the second in the same manner, with the weight attached to the bottom of the third sampler (figure 5).

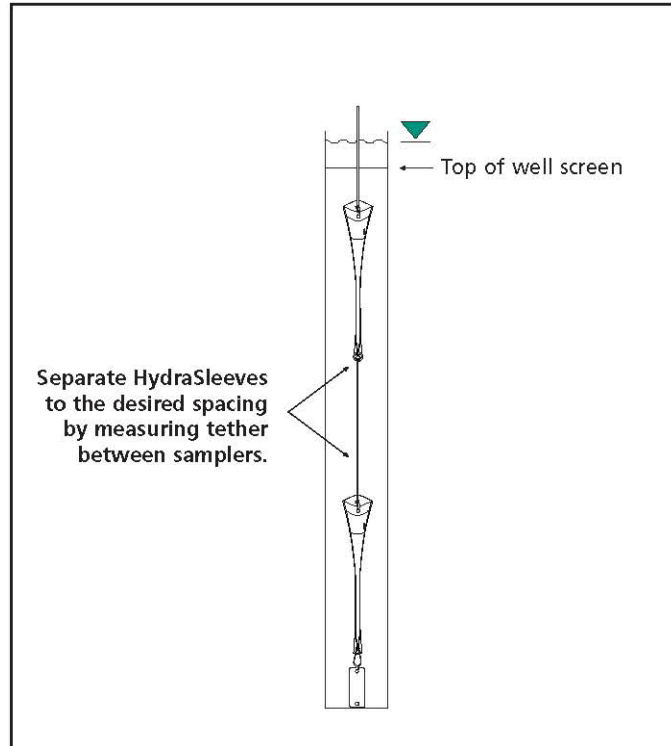

Figure 5. Alternative method for deploying multiple HydraSleeves.

In either case, when attaching multiple HydraSleeves in series, more weight may be required to hold the samplers in place in the well than would be required with a single sampler. Recovery of multiple samplers and collection of samples is done in the same manner as for single sampler deployments.

Post-Sampling Activities

The recovered HydraSleeve and the sample discharge tubing should be disposed as per the solid waste management plan for the site. To prepare for the next sampling event, a new HydraSleeve can be deployed in the well (as described previously) and left in the well until the next sampling event, at which time it can be recovered.

The weight and weight clip can be reused on this sampler after they have been thoroughly cleaned as per the site equipment decontamination plan. The tether may be dedicated to the well and reused or discarded at the discretion of sampling personnel.

References

McAlary, T. A. and J. F. Barker, 1987, Volatilization Losses of Organics During Ground-Water Sampling From Low-Permeability Materials, Ground-Water Monitoring Review, Vol. 7, No. 4, pp. 63-68

Parsons, 2005, Results Report for the Demonstration of No-Purge Ground-Water Sampling Devices at Former McClellan Air Force Base, California; Contract F44650-99-D-0005, Delivery Order DKO1, U.S. Army Corps of Engineers (Omaha District), U.S. Air Force Center for Environmental Excellence, and U.S. Air Force Real Property Agency

Robin, M. J. L. and R. W. Gillham, 1987, Field Evaluation of Well Purging Procedures, Ground-Water Monitoring Review, Vol. 7, No. 4, pp. 85-93



HYDRASleeve

Simple by Design

US Patents No. 6,481,300; No. 6,837,120; others pending

Field Manual

Introduction

The HydraSleeve groundwater sampler can be used to collect a representative sample for most physical and chemical parameters without purging the well. It collects a whole water sample from a user-defined interval (typically within the well screen), without mixing fluid from other intervals. One or more HydraSleeves are placed within the screened interval of the monitoring well, and a period of time is allocated for the well to re-equilibrate. Hours to months later, the sealed HydraSleeve can be activated for sample collection. When activated, HydraSleeve collects a sample with no drawdown and minimal agitation or displacement of the water column. Once the sampler is full, the one-way reed valve collapses, preventing mixing of extraneous, non-representative fluid during recovery.

Assembly

Assembling the HydraSleeve is simple, and can be done by one person in the field, taking only a minute or two.

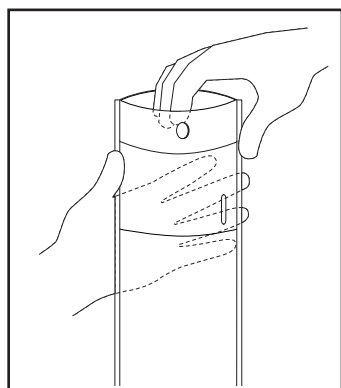

1 Remove HydraSleeve from package and grasp top to "pop" open.

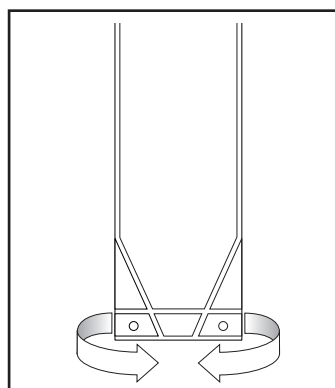

4 Fold the two holes at bottom of HydraSleeve together and attach weight

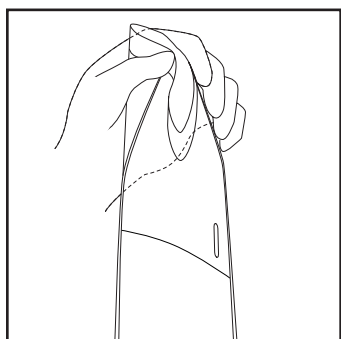

2 Squeeze side fins together at top to bend reinforcing strips outward.

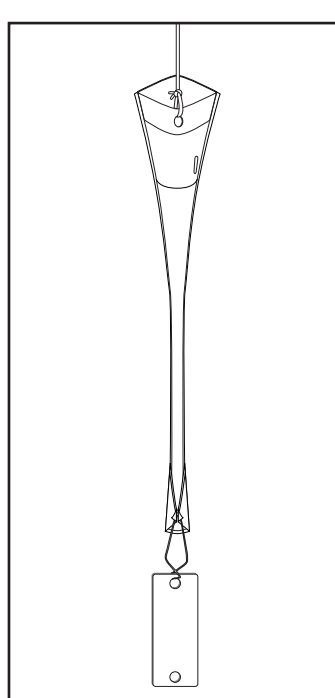

5 Sampler is ready to insert into the well.

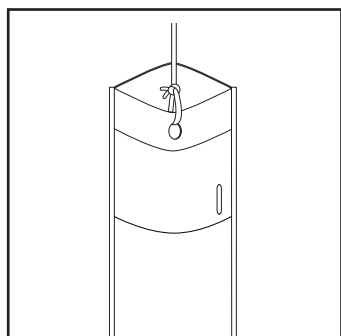

3 Attach line to hole at top of HydraSleeve.

Placing the HydraSleeve(s)

To collect a representative groundwater sample without purging, the well must be allowed time to re-equilibrate after placement of the sampler. When any device is lowered into a well, some mixing of the water column occurs. The diameter of the device and its shape greatly affect the degree of mixing. The flat cross-section of the empty HydraSleeve minimizes the disturbance to the water column as the sampler is lowered into position, reducing the time needed for the well to return to equilibrium.

There are three basic methods for holding a HydraSleeve in position as the well equilibrates.

TOP DOWN DEPLOYMENT (Figure 1)

Measure the correct amount of suspension line needed to "hang" the top of the HydraSleeve(s) at the desired sampling depth (in most cases, this will be at the bottom of the sampling zone). The upper end of the tether can be connected to the well cap to suspend the HydraSleeve at the correct depth until activated for sampling.

Note: For deep settings, it may be difficult to accurately measure long segments of suspension line in the field. Factory prepared, custom suspension line and attachment points can be provided.

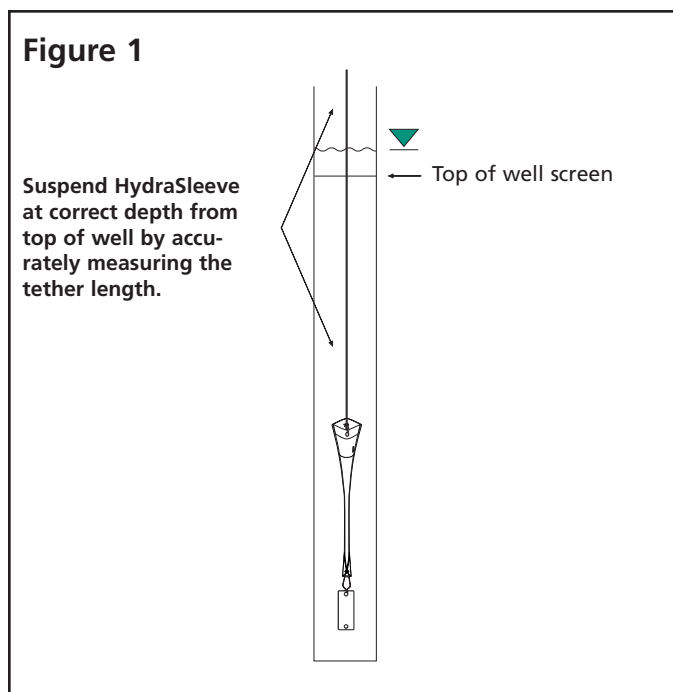

BOTTOM DEPLOYMENT (Figure 2)

Sound the well to determine the exact depth. Lower the weighted HydraSleeve into the well and let it touch the bottom. Very slowly (less than 1/2 foot per second) raise the sampler to the point where the check valve is at the depth the sample is to be collected. Attach the suspension line to the top of the well to suspend it at this depth. (It is often easier to measure a few feet from the bottom of the well up to the sample point, than it is to measure many feet from the top of the well down.)

Alternately, the sampler can be left on the bottom until the well re-equilibrates. For sampling, it can be very slowly pulled (< 1/2 fps) to sampling depth, then activated (see "Sample Collection," p. 6) to collect the sample, and retrieved to the surface.

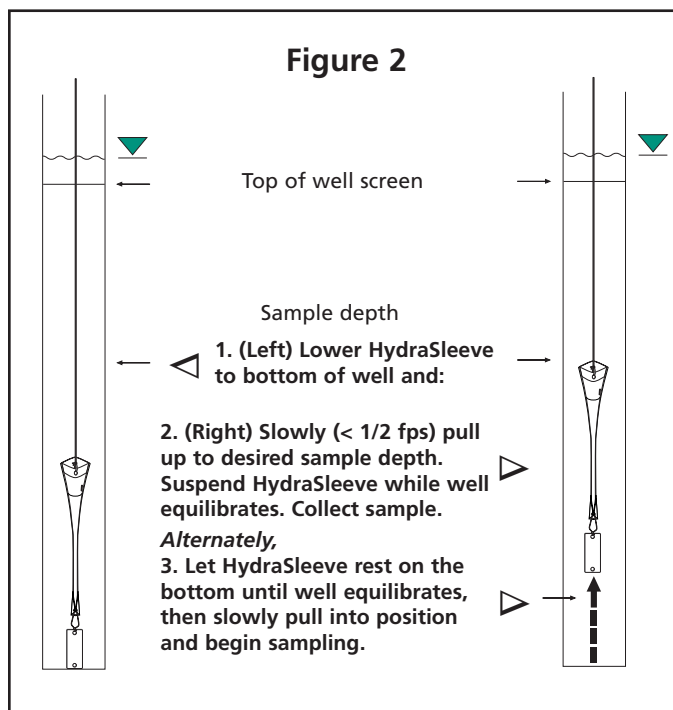

BOTTOM ANCHOR (Figure 3)

Determine the exact depth of the well.
Calculate the distance from the bottom of the well to the desired sampling depth.
Attach an appropriate length anchor line between the weight and the bottom of the sampler and lower the assembly until the weight rests on the bottom of the well, allowing the top of the sampler to float at the correct sampling depth.

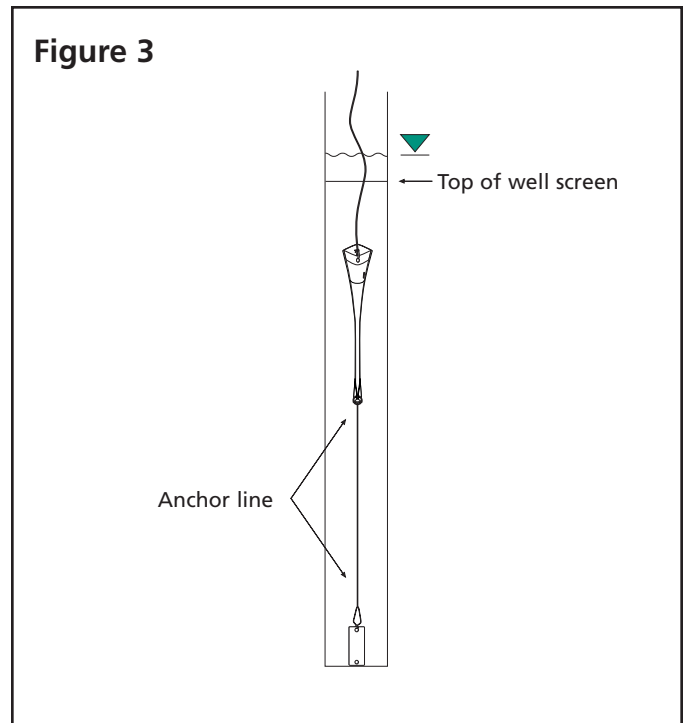

Multiple Interval Deployment

There are two basic methods for placing multiple HydraSleeves in a well to collect samples from different levels simultaneously.

ATTACHED TO A SINGLE TETHER (Figure 4)

To use 3 or more samplers simultaneously, we recommend attaching them all to a tether for support to prevent the sampling string from pulling apart. The weight is attached to a single length of suspension line and allowed to rest on the bottom of the well. The top and bottom of each HydraSleeve are attached to the tether at the desired sample intervals. Cable tie or stainless steel clips (supplied) work well for attaching the HydraSleeves to the line. Simply push one end of the clip between strands of the rope at the desired point before attaching the clip to the HydraSleeve.

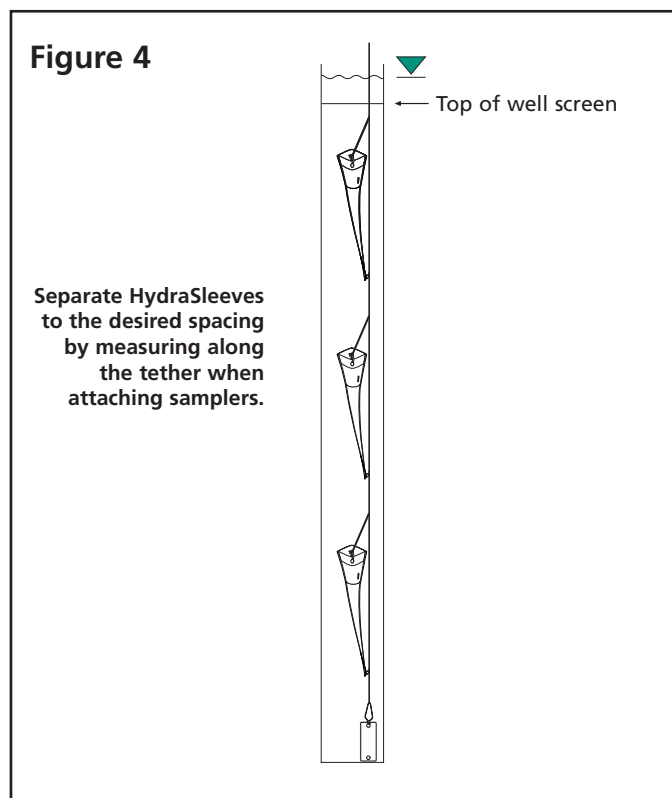

ATTACHED END TO END (Figure 5)

To place 2 or 3 stacked HydraSleeves for vertical profiling, use one of the methods described above to locate the bottom sampler. Attach the bottom of the top sampler to the top of the following HydraSleeve(s) with a carefully measured length of suspension cable. Connect the weight to the bottom sampler. Note: if many HydraSleeves are attached to a tether, more weight may be required than with a single sampler.

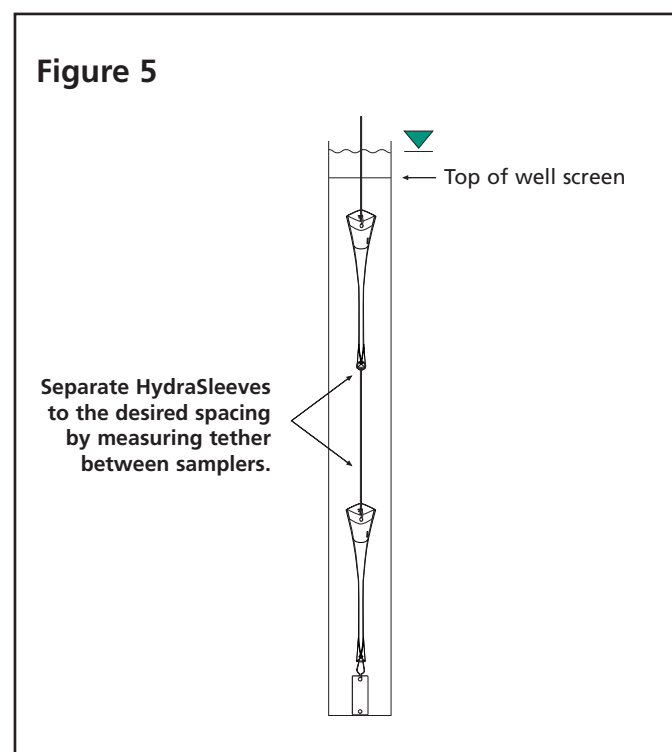

Sample Collection

The HydraSleeve must move upward at a rate of one foot per second or faster (about the speed a bailer is usually pulled upward) for water to pass through the check valve into the sample sleeve. The total upward distance the check valve must travel to fill the sample sleeve is about 1 to 2 times the length of the sampler. For example, a 24-inch HydraSleeve needs a total upward movement of 24 to no more than 48 inches to fill. The upward motion can be accomplished using one long continuous pull, several short strokes, or any combination that moves the check valve the required distance in the open position. A special technique is used for sampling low-yield wells.

CONTINUOUS PULL (Figure 6)

Pull the HydraSleeve continuously upward from its starting point at a constant 1 to 2 feet per second until full. This method usually provides the least turbid samples and is analogous to coring the water column from the bottom up.

Note: When using this method, the screen interval should be long enough so the sampler fills before exiting the top of the screen.

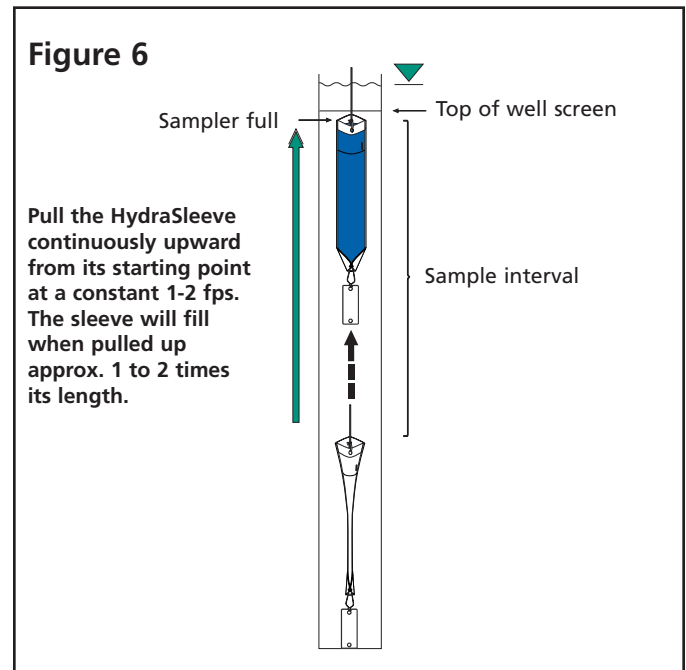

SHORT STROKES (Figure 7)

Pull the sampler upward at about 1 to 2 feet per second for the length of the sampler and let it drop back to the starting point. Repeat the cycle 3 to 5 times.

This method provides a shorter sampling interval than the continuous pull method (above), and usually reduces the turbidity levels of the sample below that of numerous rapid, short cycles (below). The sample comes from between the top of the cycle and the bottom of the sampler at its lowest point.

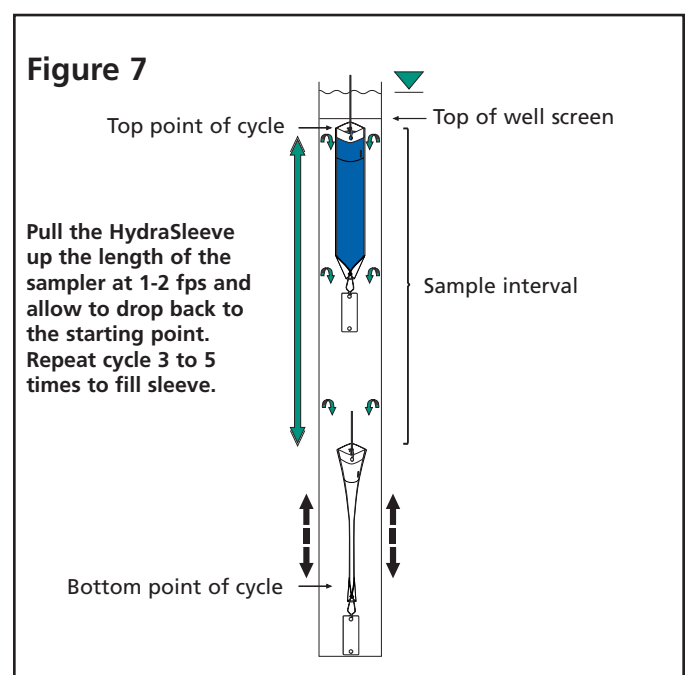

RAPID, SHORT CYCLES (Figure 8)

Cycle the HydraSleeve up and down using rapid, short strokes (6-inch cycle at a minimum of 1 cycle per second) 5 to 8 times. This method provides the shortest sampling interval. Dye studies have shown that when using this method the sample flows into the check valve from along the length of the sampler and immediately above the check valve. The sample interval is from the bottom the sampler at its lowest point in the cycle to the top of the check valve at the peak of the cycle.

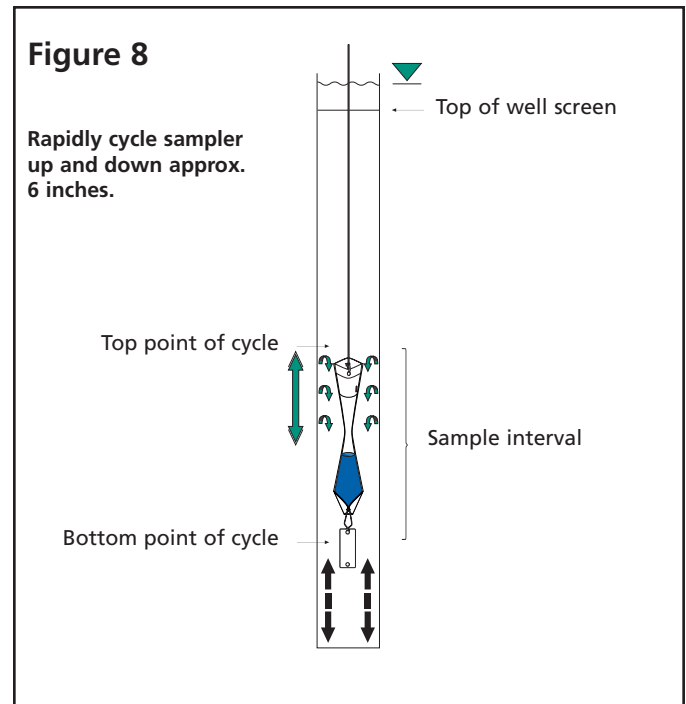

SAMPLING LOW-YIELD WELLS (Figure 9)

HydraSleeve provides the best available technology for sampling low yield wells. When pulled upward after the well re-equilibrates, the HydraSleeve will collect a water core from the top of the sampler to about its own length above that point. The sample is collected with no drawdown in the well and minimal sample agitation. An optional top weight can be attached to compress the sampler in the bottom of the well if needed for an extremely short water column. With a top weight, the check valve is pushed down to within a foot of the bottom of the well.

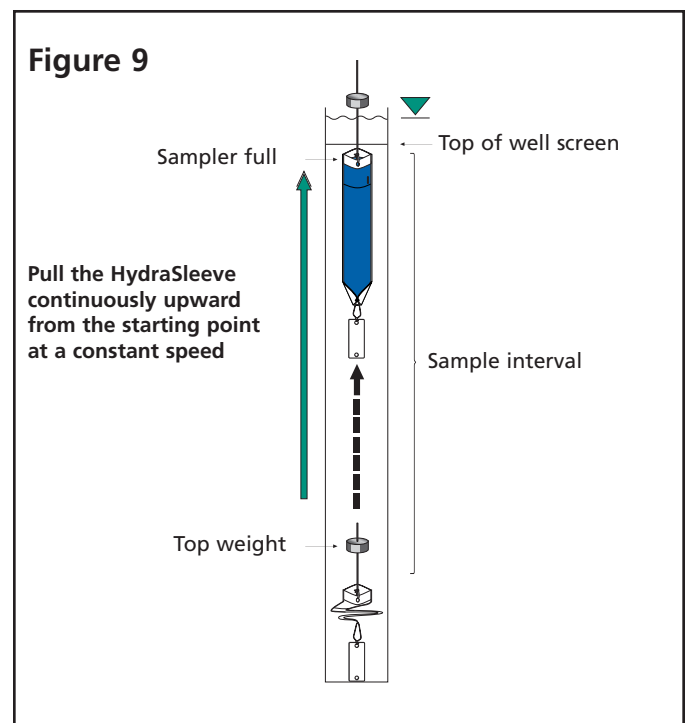

Sample Discharge

The best way to remove a sample from the HydraSleeve with the least amount of aeration and agitation is with the short plastic discharge tube (included).



First, squeeze the full sampler just below the top to expel water resting above the flexible check valve. (Photo 1, top left)



Then, push the pointed discharge tube through the outer polyethylene sleeve about 3-4 inches below the white reinforcing strips. (Photo 2, middle left)



Discharge the sample into the desired container. (Photo 3, bottom left)

Raising and lowering the bottom of the sampler or pinching the sample sleeve just below the discharge tube will control the flow of the sample. The sample sleeve can also be squeezed, forcing fluid up through the discharge tube, similar to squeezing a tube of toothpaste. With a little practice, and using a flat surface to set the sample containers on, HydraSleeve sampling becomes a one-person operation.



1680 Hickory Loop, Suite B • Las Cruces, NM 88005
Phone: 1.800.996.2225 • 1.505.523.5799 • Fax: 1.505.523.0789
www.geoinsightonline.com • KentCordry@aol.com